



TOW-TRUST TOWBARS

SIMPLY THE BEST



PART NUMBER	DESCRIPTION	YEAR	RRP NOV 2010	NOSE LOAD	MAX TOW CAP	EC 94/20	BUMP REM	BUMP CUT		WIDTH & DEPTH
BMW										
TBM914VK	5 Series Touring Est (E39)	1997 - 2004	£445.00	90	2000	✓	✓	✗		SEE FITTING
TBM2	5 Series GT (Gran Turismo)	2010>	£228.00	100	2250	✓	✓	✗		Marked Area
TBM2VK	5 Series GT (Gran Turismo)	2010>	£386.00	100	2250	✓	✓	✗		Marked Area
TBM2	5 Series Est (F11)	2010>	£228.00	100	2250	✓	✓	✗		Marked Area
TBM2VK	5 Series Est (F11)	2010>	£386.00	100	2250	✓	✓	✗		Marked Area
TBM2	5 Series Sal (F10)	2010>	£228.00	100	2250	✓	✓	✗		Marked Area
TBM2VK	5 Series Sal (F10)	2010>	£386.00	100	2250	✓	✓	✗		Marked Area
TBM915VK	X5 (E70)	2007>	£430.00	140	3500	✓	✓	✗		SEE FITTING
TBM915	X6 (E71)	2008>	£224.00	140	3500	✓	✓	✗	✓	SEE FITTING
TBM915VK	X6 (E71)	2008>	£430.00	140	3500	✓	✓	✗	✓	SEE FITTING
CHRYSLER / JEEP										
TCH9	Dodge Avenger	2007>	£215.00	80	1500	✓	✓			
TCH9	Sebring	2007>	£215.00	80	1500	✓	✓	✗		100 x 40
CITROEN										
TP431B	DS4	2011>	£161.00	76	1873	✓				
TP431BVK	DS4	2011>	£355.00	76	1873	✓				
FIAT										
TF1036	Panda (Not 4 x 4)	2004>	£177.00	60	900	✓	✓			
FORD										
TF169	Focus 2/3/4 Est (Inc. Sports Model) Inc 2010 Facelift	2005>	£160.00	80	1500	✓	✓			
TF169D	Focus 2/3/4 Est (Inc. Sports Model) Not 2010 Facelift	2005 -2010	£260.00	75	1500	✓	✓			

NEW TOWBARS

KEEP UP TO DATE: WWW.TOW-TRUST.CO.UK

PART NUMBER	DESCRIPTION	YEAR	RRP NOV 2010	NOSE LOAD	MAX TOW CAP	EC 94/20	BUMP REM	BUMP CUT		WIDTH & DEPTH
HONDA										
TH3	Jazz	2008>	£195.00	70	1500	✓	✓	✗		Marked Area
TH3VK	Jazz	2008>	£360.00	70	1500	✓	✓	✗		Marked Area
HYUNDAI										
THY7AHK	Santa Fe	2006>	£370.00	100	2200	✓				
THY9HK	i10	2008>	£330.00	70	700	✓				
THY10HK	i20	2008>	£325.00	65	1200	✓				
TK12	ix35	2010>	£218.00	80	2000	✓				
TK12VK	ix35	2010>	£345.00	80	2000	✓				
KIA										
THY7AHK	Sorento III	2009>	£370.00	100	2200	✓				
TK12	Sportage 3	2010>	£218.00	80	2000	✓				
TK12VK	Sportage 3	2010>	£345.00	80	2000	✓				
LANDROVER										
TL259HK	Freelander 2 (No Bumper Cut)	2006>	£330.00	150	2000	✓				
TL249	Range Rover (Not Sport) (Inc. Vogue) (Inc. OVERFINCH)	2002>	£240.00	150	3500	✓	✓			
TL249D	Range Rover (Not Sport) (Inc. Vogue) (Inc. OVERFINCH)	2002>	£418.00	150	3500	✓	✓			
TL249VK	Range Rover (Not Sport) (Inc. Vogue) (Inc. OVERFINCH)	2002>	£595.00	150	3500	✓	✓			
RANGE ROVER										
TL249	Range Rover (Not Sport) (Inc. Vogue) (Inc. OVERFINCH)	2002>	£240.00	150	3500	✓	✓			
TL249D	Range Rover (Not Sport) (Inc. Vogue) (Inc. OVERFINCH)	2002>	£418.00	150	3500	✓	✓			
TL249VK	Range Rover (Not Sport) (Inc. Vogue) (Inc. OVERFINCH)	2002>	£595.00	150	3500	✓	✓			
RENAULT										
TR849	Mascott Chassis Cab	2005 - 2010	£193.00	75	3500					
TR849	Mascott Van	2005 - 2010	£193.00	75	3500					
VAUXHALL / BEDFORD / OPEL										
TV4	Meriva	2010>	£190.00	75	1500	✓	✓			
TV4VK	Meriva	2010>	£355.00	75	1500	✓	✓			

NEW TOWBARS

KEEP UP TO DATE: WWW.TOW-TRUST.CO.UK





TOW-TRUST TOWBARS

SIMPLY THE BEST

COMING SOON

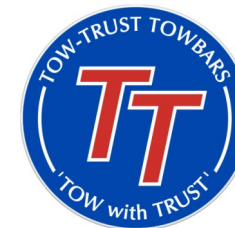
PLEASE RING FOR DETAILS



PART NUMBER	DESCRIPTION	YEAR	RRP NOV 2010	NOSE LOAD	MAX TOW CAP	EC 94/20	BUMP REM	BUMP CUT		WIDTH & DEPTH
MERCEDES										
TM12	E Class Est (W212) (Inc AMG)	2010>	TBA	84	2500	✓	✓			
TM12VK	E Class Est (W212) (Inc AMG)	2010>	TBA	84	2500	✓	✓			
TM11	E Class Sal (W212)	2009>	TBA	84	2100	✓	✓			
TM11VK	E Class Sal (W212)	2009>	TBA	84	2100	✓	✓			
NISSAN										
TN10HK	JUKE 2WD	2010>	TBA	75	1500	✓	✓			
PEUGEOT										
TP9	508 Est / SW	2011>	TBA	75	1900	✓	✓			
TP9VK	508 Est / SW	2011>	TBA	75	1900	✓	✓			
TOYOTA										
TT10	VERSO (R2) (Not VERSO S)	2009>	TBA	55	1430	✓	✓			
TT10VK	VERSO (R2) (Not VERSO S)	2009>	TBA	55	1430	✓	✓			

NEW TOWBARS

KEEP UP TO DATE: WWW.TOW-TRUST.CO.UK



TOW-TRUST TOWBARS

SIMPLY THE BEST

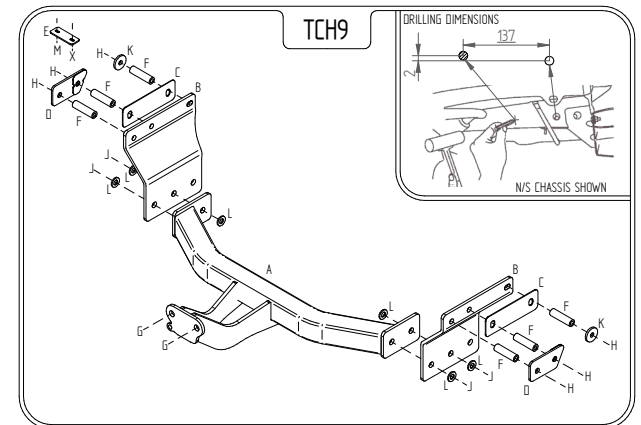
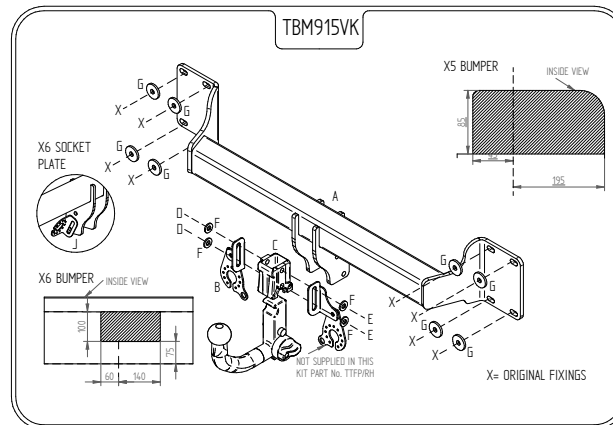
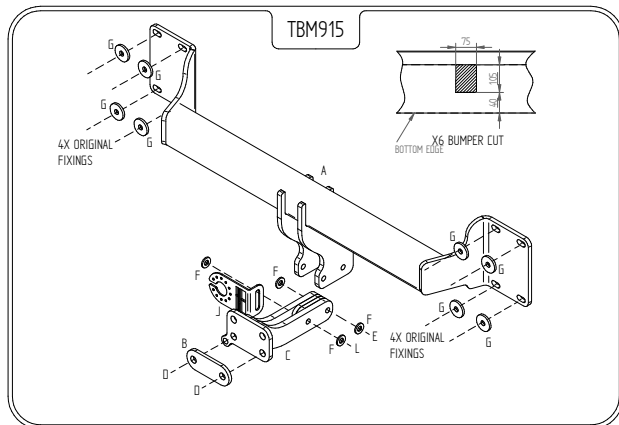
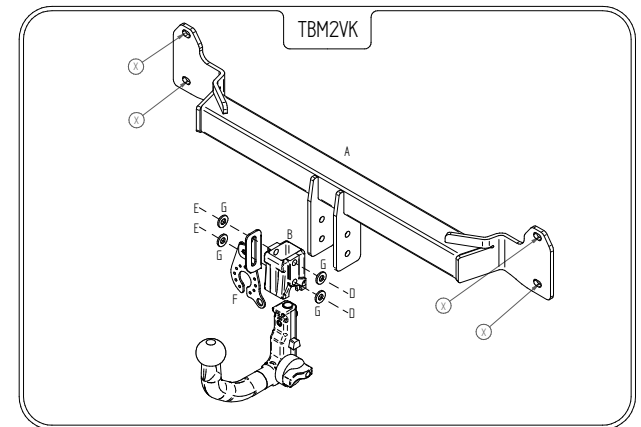
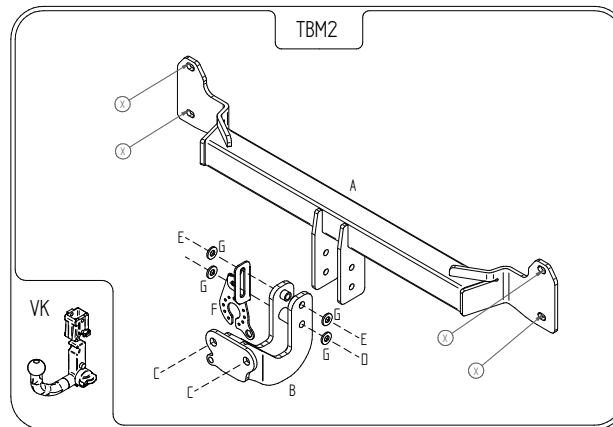
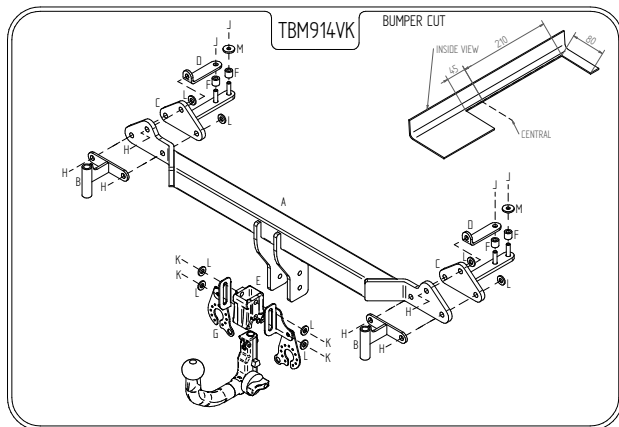

NEW TOWBARS

KEEP UP TO DATE: WWW.TOW-TRUST.CO.UK



TOW-TRUST TOWBARS

SIMPLY THE BEST

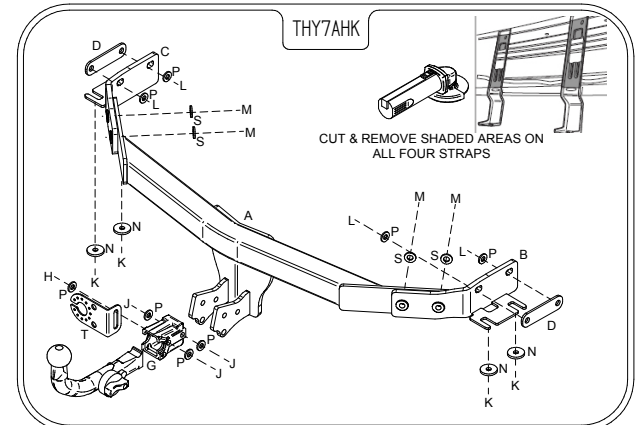
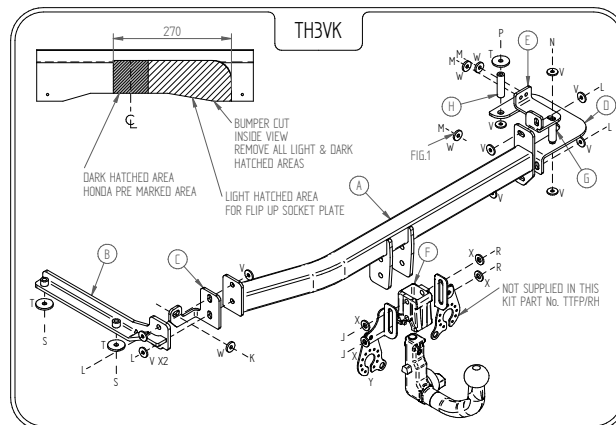
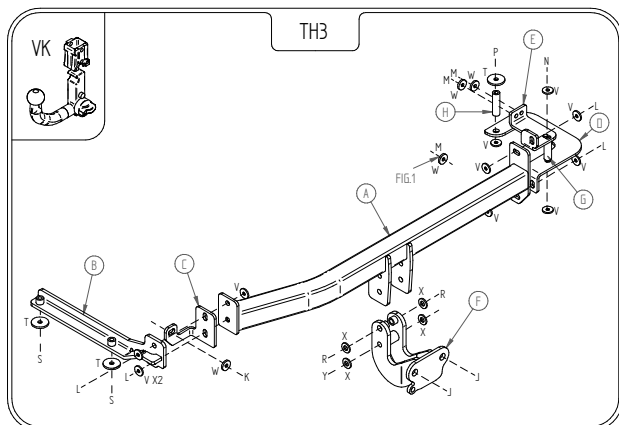
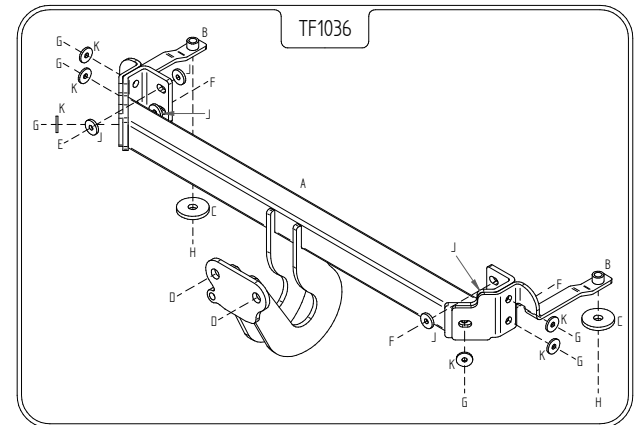
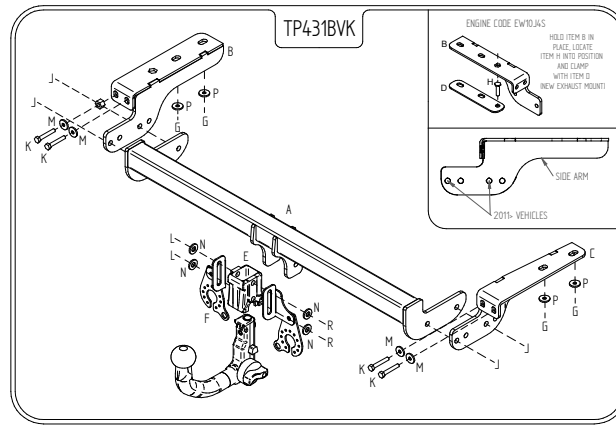
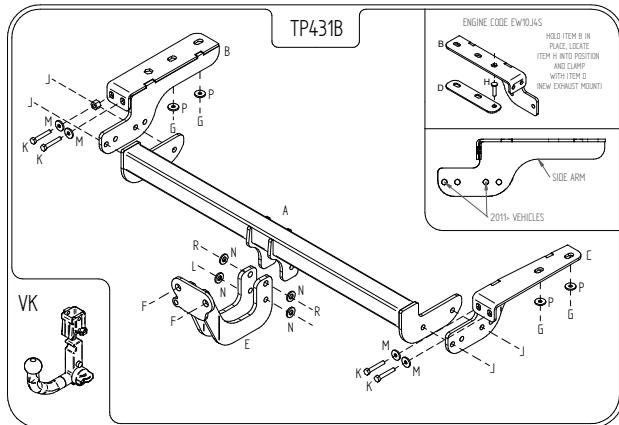

NEW TOWBARS

KEEP UP TO DATE: WWW.TOW-TRUST.CO.UK



TOW-TRUST TOWBARS

SIMPLY THE BEST

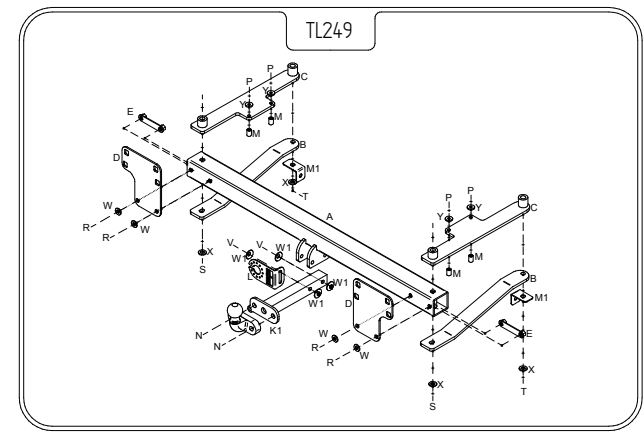
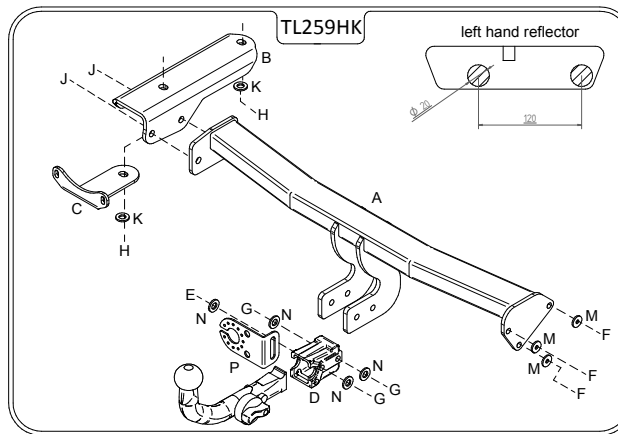
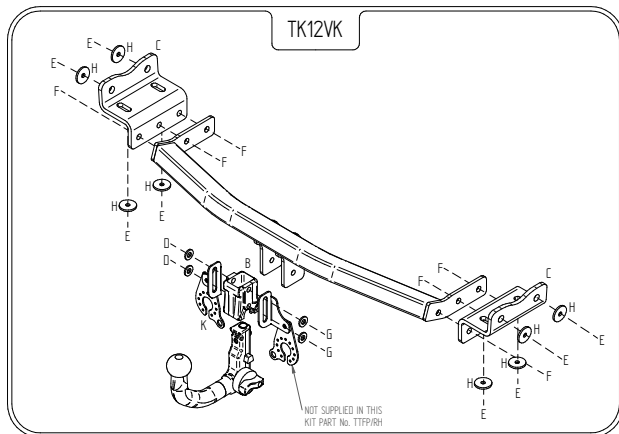
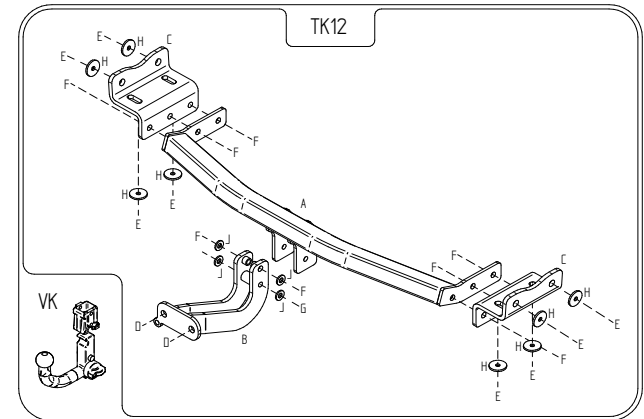
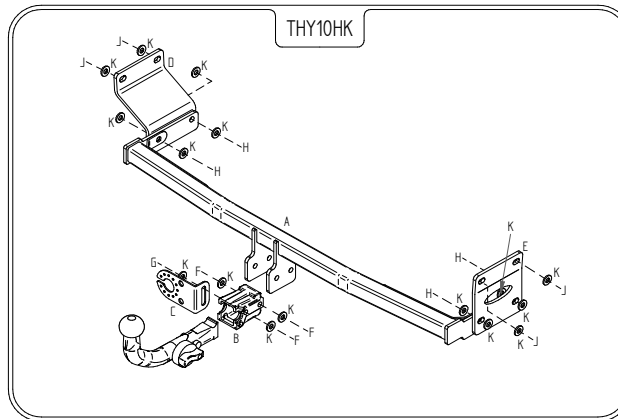
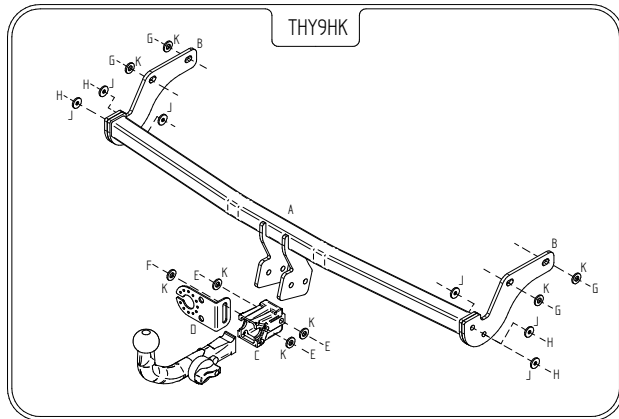

NEW TOWBARS

KEEP UP TO DATE: WWW.TOW-TRUST.CO.UK



TOW-TRUST TOWBARS

SIMPLY THE BEST

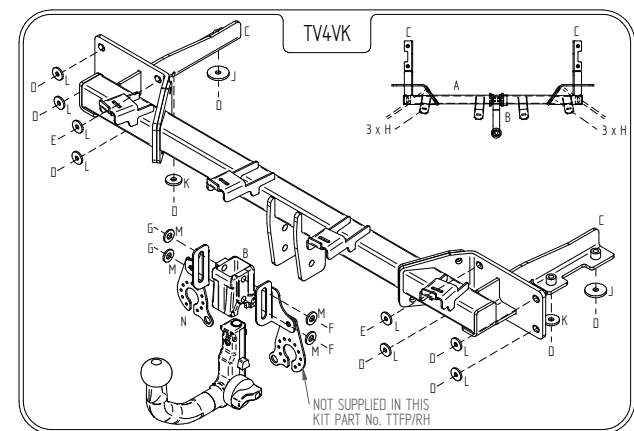
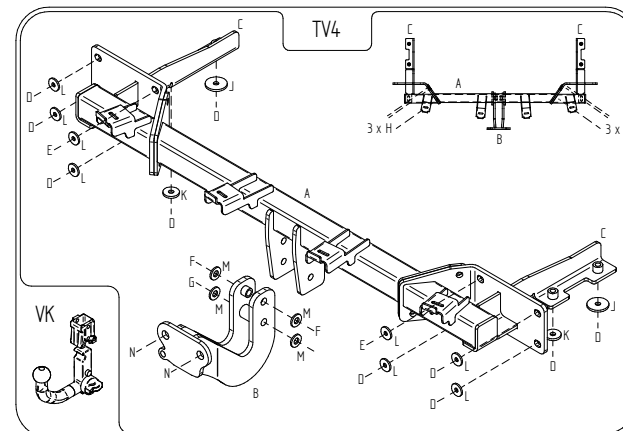
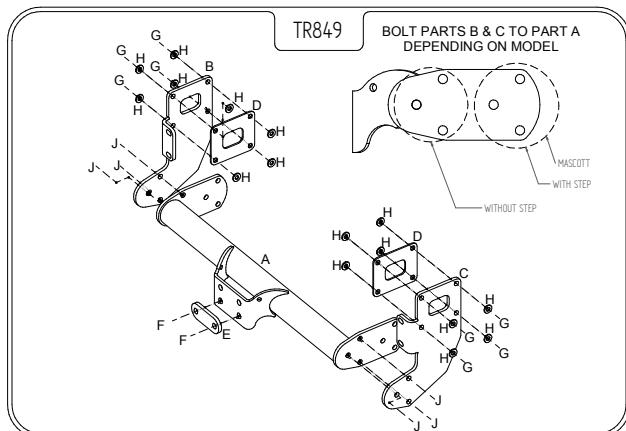
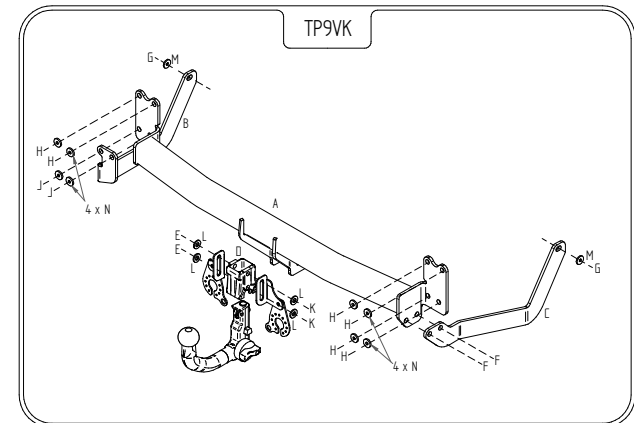
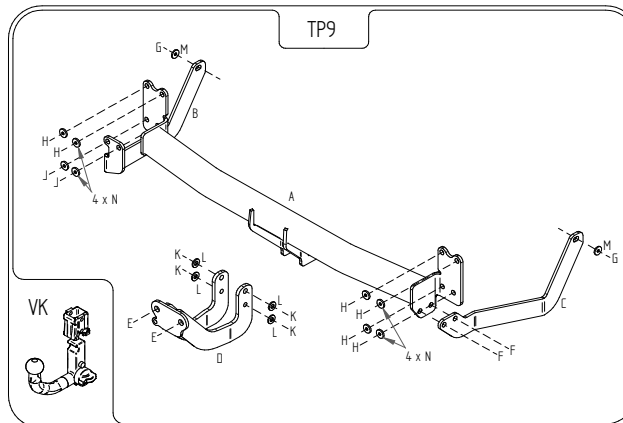
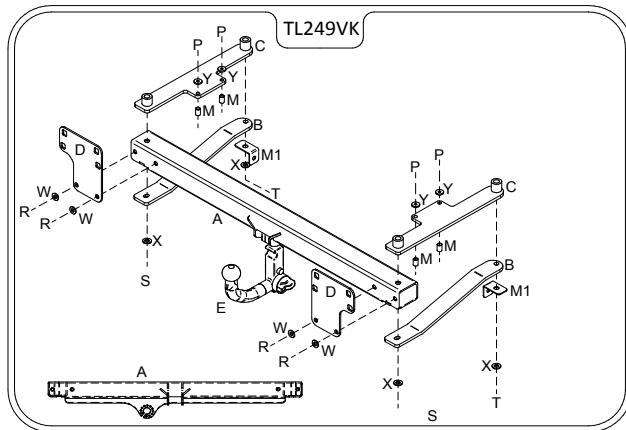

NEW TOWBARS

KEEP UP TO DATE: WWW.TOW-TRUST.CO.UK



TOW-TRUST TOWBARS

SIMPLY THE BEST

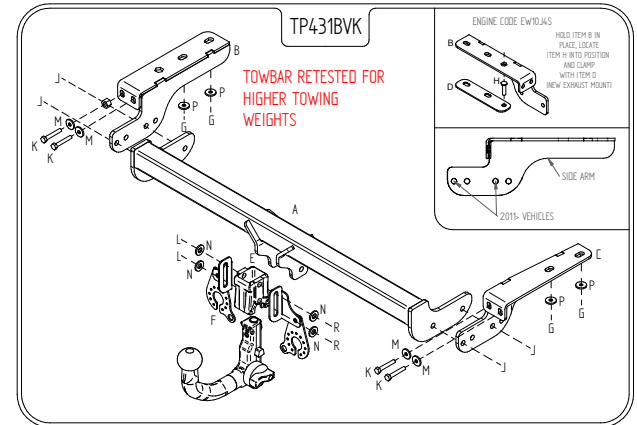
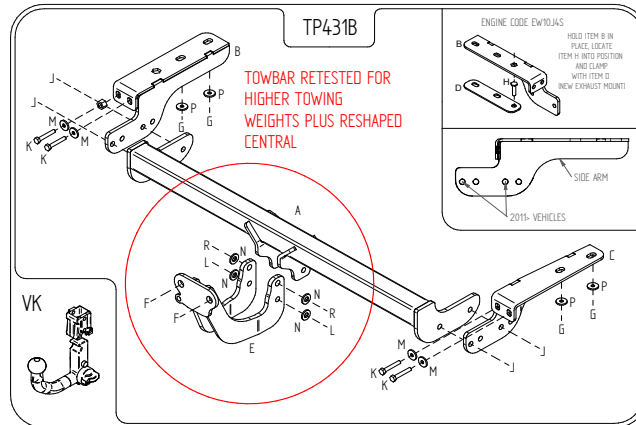
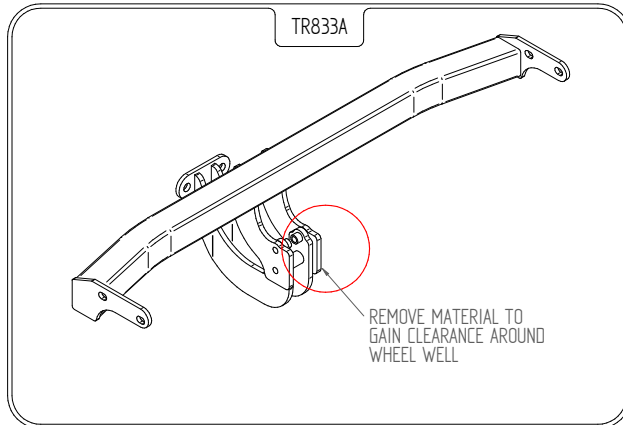
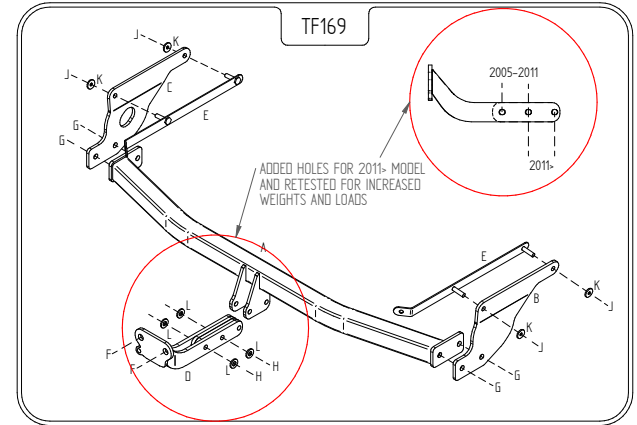
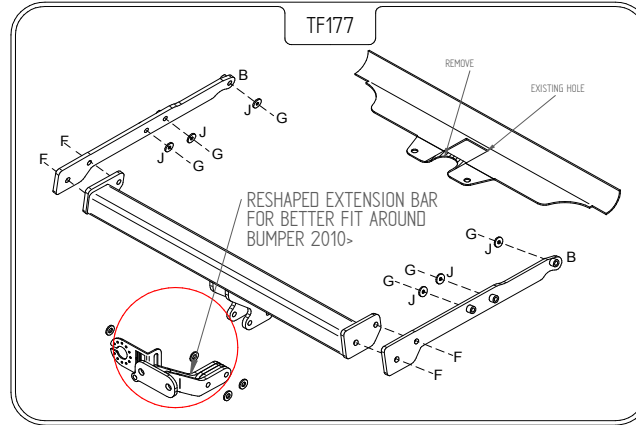
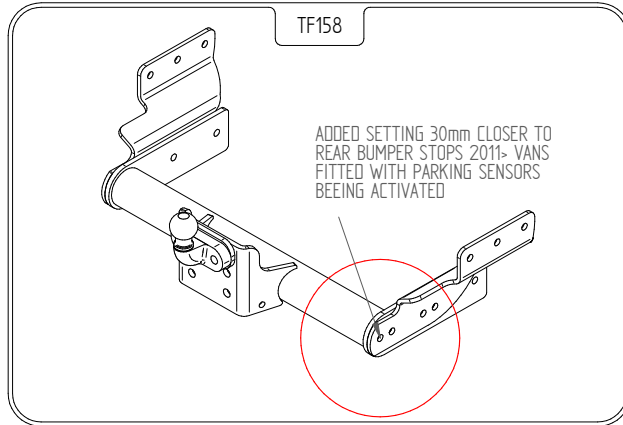

MODIFIED TOWBARS FOR BETTER FITMENT

KEEP UP TO DATE: WWW.TOW-TRUST.CO.UK



TOW-TRUST TOWBARS

SIMPLY THE BEST

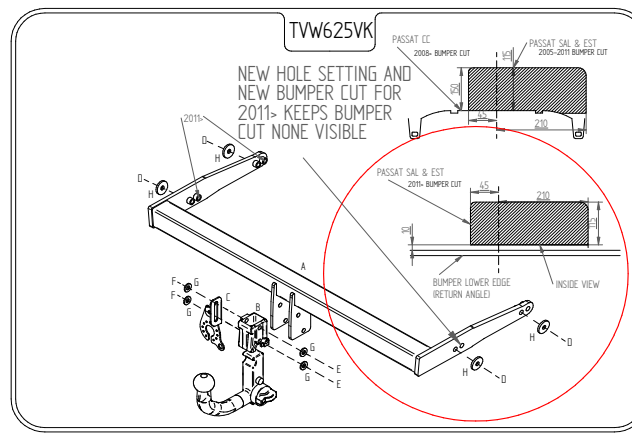
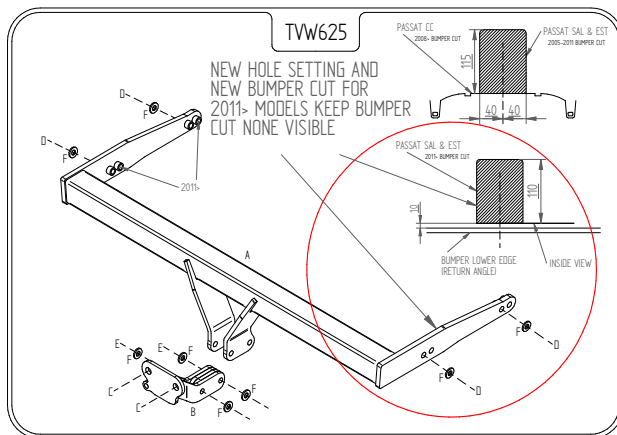
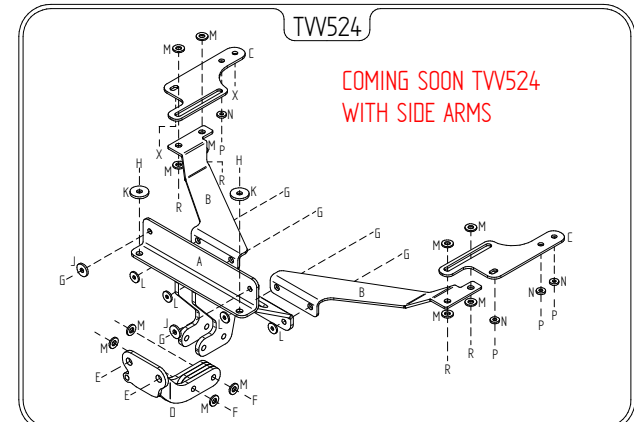
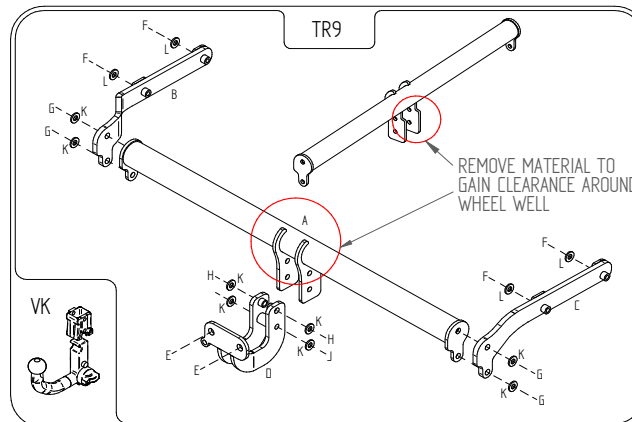
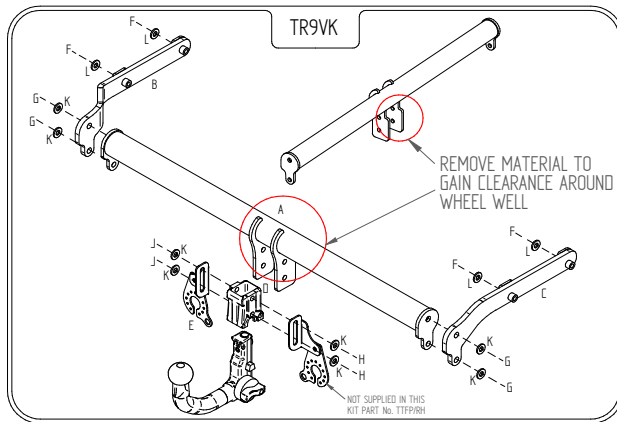

Please feel free to call us any time with information, suggestions and to prioritise Towbars that are not available (TBA) on list. Here at TOW-TRUST we pride ourselves on our personal service and commitment, we listen to our customers and follow up any information provided. This helps us to continue designing and manufacturing the best product in the Towing Industry. Many Thanks.

Tom Miller (01827) 717412

MODIFIED TOWBARS FOR BETTER FITMENT

KEEP UP TO DATE: WWW.TOW-TRUST.CO.UK



TOW-TRUST TOWBARS

SIMPLY THE BEST



***** STOP PRESS *****

**COMING SOON TOW-TRUST
SWAN NECK TOWBARS**

