



# Tow-Trust Towbars

Important: Please read General Notes overleaf before fitting

Issue 2

TA1016

AUDI A5 2007> (B8)

AUDI A4 SAL & EST 2008> (B8)

Item	Qty	Description	Item	Qty	Description
A	1	Crossmember	E	2	M16 x 50 Bolts, Nuts & Washers
B	2	Side Arms	F	2	M12 x 85 Grade 10.9 Bolts & Nyloc Nuts
C	1	Extension Bar	G	4	M10 x 100 Bolts, 2 Nuts & 4 S/P Washers
D	2	30 x 65 Spacer	H	2	M10 x 30 Bolts & S/P Washers
			J	2	M14 x 110 Bolts & Nyloc Nuts
			K	4	14 x 30 Flat Washers
			L	4	12 x 25 Flat Washers
			M	6	10 x 30 Flat Washers
			P	1	Socket Plate

1. Remove boot floor and tie down hooks, ease side panels enough to reveal Towbar mounting points.
2. Remove mud flaps if fitted and rear light clusters.
3. Remove the rear bumper three fixings around wheel arch, four fixings on lower edge, one fixing through back panel and one retaining pin under light cluster.
4. Cut a section from the lower edge of the bumper 65mm wide x 95mm deep. SEE SKETCH.
5. Remove the sensor from the bumper beam. (If fitted)
6. Remove the bumper beam. (This is not refitted with the towbar.)
7. Temporarily lower the rear exhaust silencer.
8. Locate item **B** into the open ends of each chassis, using item **G** with item **M** loosely bolt into place.
9. Using item **H** bolt and fully tighten item **A** to items **B**.
10. Using item **J** and item **K** bolt item **A** through the vertical point to item **B**.
11. Using original fixings refit the sensor to new mount on item **A**.
12. Fully tighten all nuts and bolts and ensure the towbar is rigid and secure.
13. Refit exhaust silencer.
14. Re-fit the rear bumper. (Take care not to break top central bumper locator)
15. Using item **F** with item **L** bolt item **C** and item **P** to item **A**.
16. Using item **E** bolt the ball bracket (not supplied in this kit) to the mounting plate, fully tighten all remaining nuts and bolts
17. Refit rear trim inside the boot.

#### Note:

1. Recommended Torque Setting for M12 Grade 10.9 -139 Nm. (For other Torque Settings see notes overleaf.)
2. Nose load limits and vehicle manufacturers trailer / caravan weight limits must be observed.

BUMPER CUT DETAILS ( THIS IS NOT A SCALED TEMPLATE )

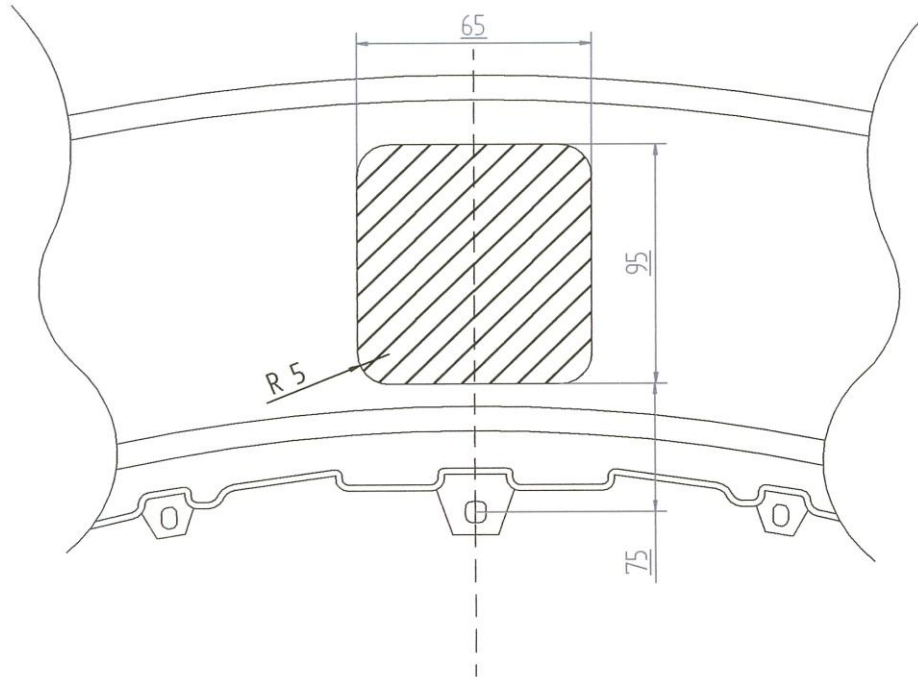

## TA 1016

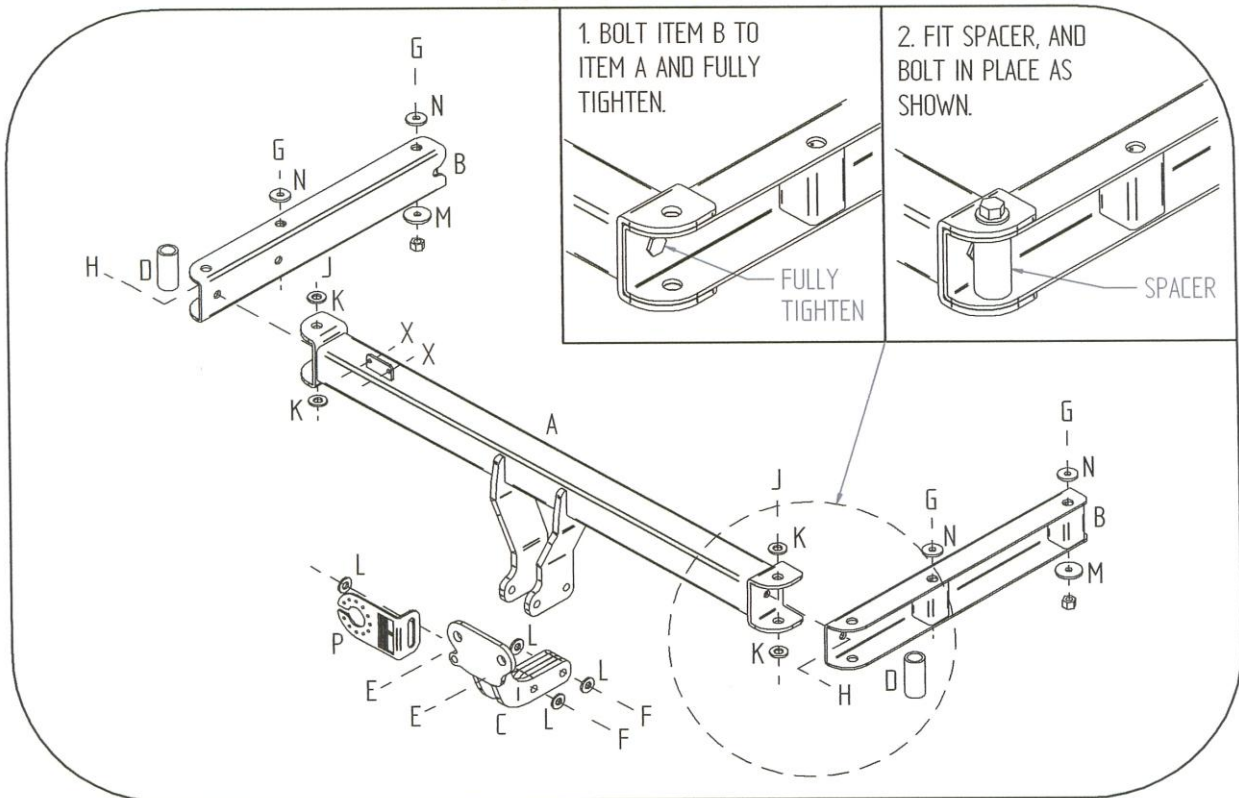

**Tow with Trust**