



Tow-Trust Towbars

Important: Please read General Notes overleaf before fitting

Issue 2

TC711 Mitsubishi L200 2WD & 4WD Pick Up '96>

Item	Qty	Description	Item	Qty	Description
A	1	Crossmember	G	2	M16 x 50 Bolts, Nuts & S/P Washers
B	2	Side Arms	J	14	M12 x 40 Bolts, 16 Nyloc Nuts & 2 S/P Washers
C	2	Handed Clamp Plates	K	8	12 x 25 Flat Washers
D	2	Angle Brackets			
E	1	10mm Spacer Plate			

1. Remove the rear under-run bar (if fitted).
2. Using item J with item K loosely bolt item B to the existing holes in each chassis member. Use item C with nyloc nuts provided on forward holes (see sketch).
3. Using item J loosely bolt item D to item B and to the existing hole in the underside of each chassis member.
4. Using item J bolt item A to item B (see sketch).
5. Using item G with item E bolt the ball bracket and wiring plate (not supplied in this kit) to the mounting plate.
6. Fully tighten all nuts and bolts and ensure the towbar is rigid and secure.

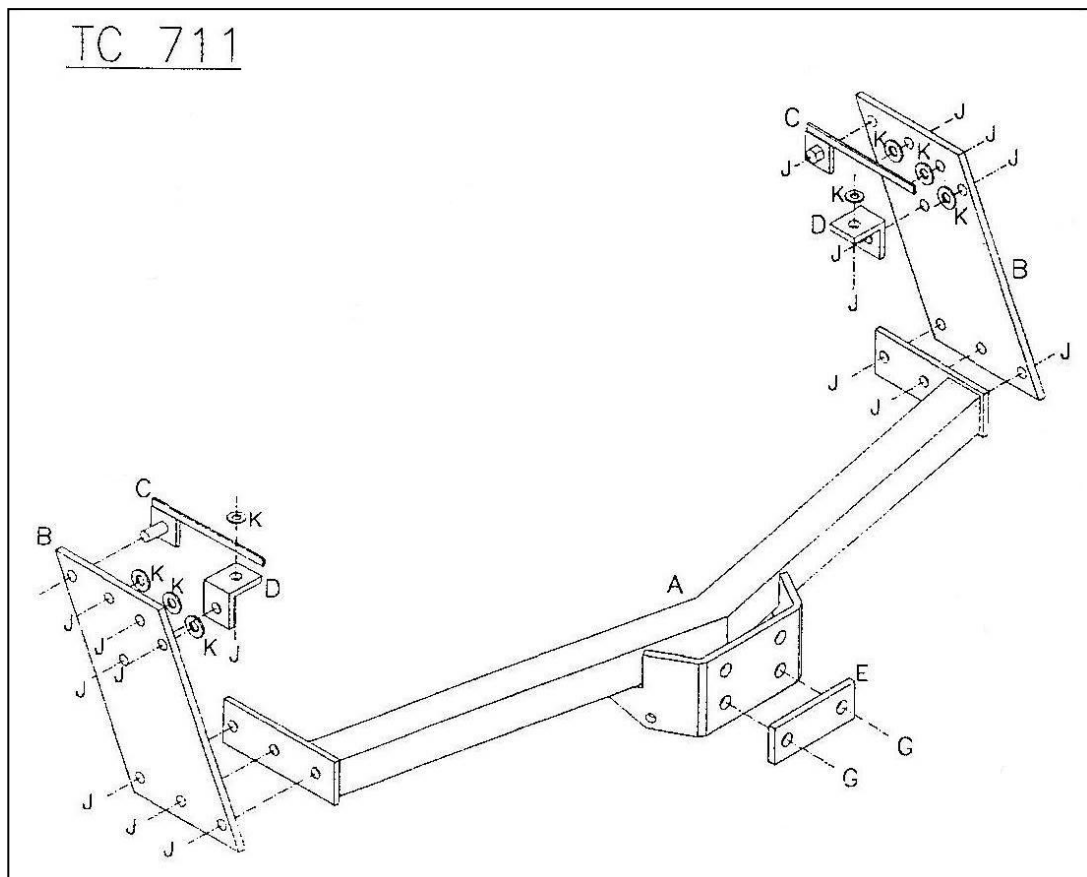

Note:

1. Recommended Torque Setting for M12 Grade 10.9 -139 Nm. (For other Torque Settings see notes overleaf.)
2. Nose load limits and vehicle manufacturer's trailer / caravan weight limits must be observed.