



# Tow-Trust Towbars

Important: Please read General Notes overleaf before fitting

Issue 1

**TCH 11**  
**DODGE NITRO 2007>**  
**JEEP CHEROKEE 2008>**

Item	Qty	Description	Item	Qty	Description
A	1	Crossmember	E	2	M16 x 50 Bolts, Nuts & S/P Washers
B	2	Handed Side Arms	F	6	M12 x 40 Bolts & S/P Washers
C	1	Extension Bar	G	6	M12 x 35 Bolts, 4 Nuts & 6 S/P Washers
D	1	Angle Socket Plate	H	3	M12 x 40 Bolts & S/P Washers
			J	4	12 x 25 Flat Washers
			K	6	12 x 40 Flat Washers
			L	1	M12 x 45 Bolt & S/P Washer

1. Remove three fixing securing the Towing eye to the chassis member and discard. (Towing eye not refitted with Towbar assembly).
2. Remove the fixing from the L/H chassis member securing brace at forward point.
3. Using item **F** with item **K** bolt side arms **B** to each correct chassis member. (NOTE: on the L/H chassis member refit brace on top of arm)
4. Using item **G** bolt item **A** between items **B**.
5. Using item **H** with item **J** and item **L** with item **J** (NOTE: position of item **L**) bolt item **C** and **D** to item **A**.
6. Using item **E** bolt the ball bracket (not supplied in this kit) to item **C**.
7. Fully tighten all nuts and bolts ensuring Towbar is rigid and secure.

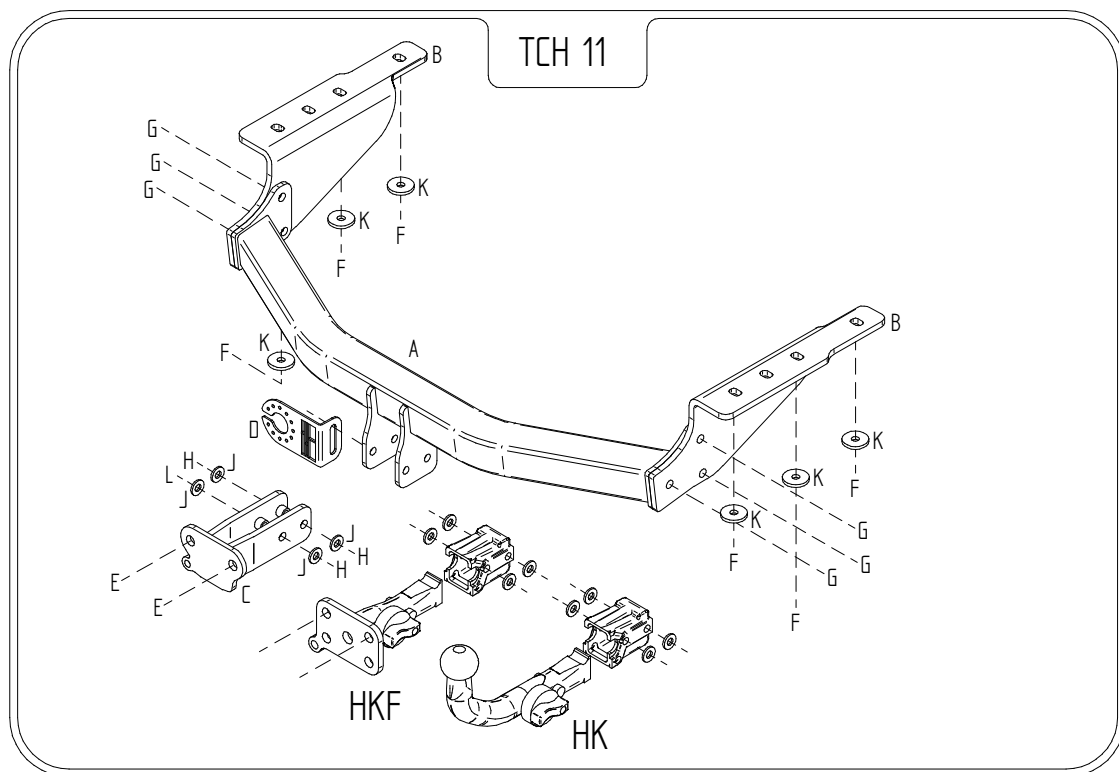

**Note:**

1. Recommended Torque Setting for M12 Grade 10.9 -139 Nm. (For other Torque Settings see notes overleaf.)
2. Nose load limits and vehicle manufacturer's trailer / caravan weight limits must be observed.