



Tow-Trust Towbars

Important: Please read General Notes overleaf before fitting

Issue 3

TCN2 PEUGEOT BIPPER CITROEN NEMO FIAT FIORINO 2008>

Item	Qty	Description	Item	Qty	Description
A	1	Crossmember	H	2	M16 x 40 Bolts, Nuts & Washers
B	1	R/H Side Arm	J	2	M12 x 85 Grade 10.9 Bolts & Nyloc Nuts
C	1	L/H Side Arm	K	4	M10 x 100 Bolts, Nuts & S/P Washers
D	1	Extension Bar	L	6	M12 x 35 Bolts, 4 Nuts & 6 S/P Washers
E	1	L/H Drilling Template	M	10	12 x 25 Flat Washers
F	1	R/H Drilling Template	N	4	10 x 25 Flat Washers
G	4	19 x 68 Spacer Bush	P	4	10 x 40 Flat Washers

1. Lower the spare wheel.
2. Remove the three vertical fixings holding the spare wheel mechanism and lower, this will allow you to drill the chassis square through both faces.
3. Remove the blanking grommets from the bottom face at the rear of each chassis member.
4. Clear chassis of any mastic ready for markings the holes.
5. Using item **E** (L/H drilling template) align the hole in the bottom face of the chassis with the hole in the template and mark the small holes in template for drilling. (See sketch for orientation of template).
6. Repeat process with item **F** on R/H chassis.
7. Open outside face of chassis only to 20MM ready for spacer bushes. Note; The rear most mounting point can be drill through plastic wheel arch.
8. Undo plastic fixing securing wheel arch liner.
9. Insert item **G** into chassis with items **K** and items **P**, on the rear most mounting point place item **P** in between chassis and wheel arch liner. Note; do not have item **P** on top of wheel arch liner.
10. Using the nuts provided in item **K** with item **N** bolt the side arms item **B** and item **C** to the inside face of each chassis.
11. Using item **L** with item **M** bolt item **A** to the side arms.
12. Using item **J** with item **M** bolt item **D** to item **A**.
13. Using item **H** bolt the ball bracket and wiring plate (not supplied on this kit) to the face plate of item **D**.
14. Fully tighten all nuts and bolts and ensure towbar is rigid and secure.

Note:

1. Recommended Torque Setting for M12 Grade 10.9 -139 Nm. (For other Torque Settings see notes overleaf.)
2. Nose load limits and vehicle manufacturers trailer / caravan weight limits must be observed.

TCN 2

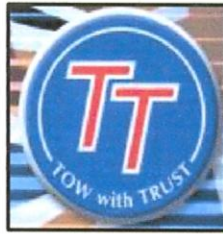

PEUGEOT BIPPER
CITROEN NEMO
FIAT FIORINO
2008>

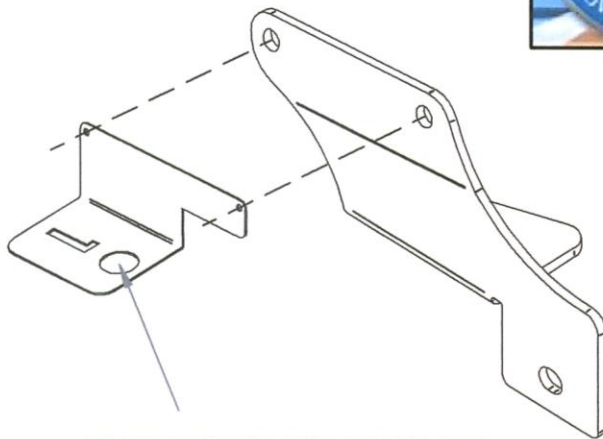

REMOVE GROMMET FROM BOTTOM FACE
OF CHASSIS TO ALIGN ITEM E (DRILLING TEMPLATE)

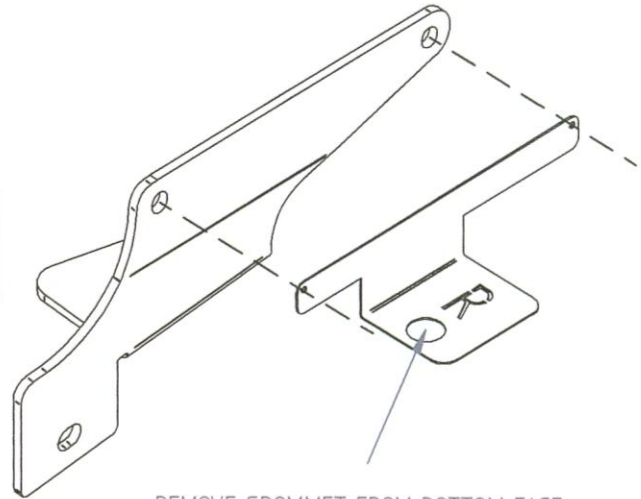

REMOVE GROMMET FROM BOTTOM FACE
OF CHASSIS TO ALIGN ITEM F (DRILLING TEMPLATE)

USE DRILLING TEMPLATES AND DISCARD.
THESE TEMPLATES ARE NOT PART OF THE
TOWBARS INSTALATION

