



Tow-Trust Towbars

Important: Please read General Notes overleaf before fitting

Issue 3

TF1029 Fiat Marea Weekend '97>

Item	Qty	Description	Item	Qty	Description
A	1	Crossmember	J	4	M16 x 50 Bolts Nuts & Washers
B	1	Drop Plate	K	2	M10 x 120
C	1	Extension Bar	L	4	M10 x 90
D	2	Clamp Plates	M	8	M8 x 30
E	1	Angle Bracket	N	1	M8 x 50
F	2	19 x 82 Spacer Tubes	P	4	M10 x 65 Bolts & S/P Washers only
G	4	19 x 60 Spacer Tubes	R	8	10 x 25 Flat Washers
H	1	19 x 20 Spacer Tube	S	8	8 x 25

1. Remove the Towing eye (this is no longer required). Remove the exhaust bracket and heat shield (if fitted) the exhaust bracket bolt is no longer required.
2. Remove the central bumper section. (6 posi drive screws 3 on the top and 3 on the bottom). Remove the cover strip from the rear panel and the two rear belt retainers. Remove floor covering and spare wheel.
3. Using item **M** temporarily bolt item **A** to the underside of the chassis. Using the holes in item **A** as a jig, drill four 11mm holes up into the chassis. Remove item **A** at this stage.
4. Place item **D** inside the boot (handed) **NOTE** trim will have to be cut to accommodate the plates. Use the belt retaining bolts to locate item **D** in correct position. Remove all mastic so that the plates sit correctly on the boot floor. Using the holes in item **D** as jigs, drill down two 11mm holes (in line with chassis) also drill the three remaining 9mm holes in the boot floor. (Repeat this on the opposite side) remove item **D** and open the 11mm holes out to 20mm each side in the top skin only.
5. Using item **L** and item **G** and the existing belt retaining bolt locate item **D** into position. Using item **M** with item **S** bolt and fully tighten these bolts.
6. Position item **A** on the underside of the chassis and secure to bolts **L** already in position. Using item **M** and item **S** secure item **A** on the right hand side. Temporarily put item **N** into position on the left hand side.
7. Using item **P** with item **R** loosely bolt item **B** to item **A**.
8. Using the holes in item **B** as a jig, drill two 11mm holes through the rear panel into the boot. Remove item **B** and open the outer holes only to 20mm.
9. Place item **E** inside the boot over the freshly drilled holes and using item **K** with item **F** loosely bolt item **B** back into position. Using item **P** with item **R** bolt item **B** to item **A**.
10. Using item **N** re-bolt exhaust bracket with item **H** between item **A** and the exhaust bracket.
11. Using item **J** bolt item **C** to item **B**.
12. Using item **J** bolt the ball bracket and wiring plate (not supplied in this kit) to the mounting plate.
13. Fully tighten all nuts and bolts and ensure the towbar is rigid and secure.
14. Replace the heat shield (if fitted), central bumper section, cover strip and the belt retainers. Replace covering from the rear panel and the spare wheel.

Note: nose load limits and vehicle manufacturers trailer / caravan weight limits must be observed.

TF 1029

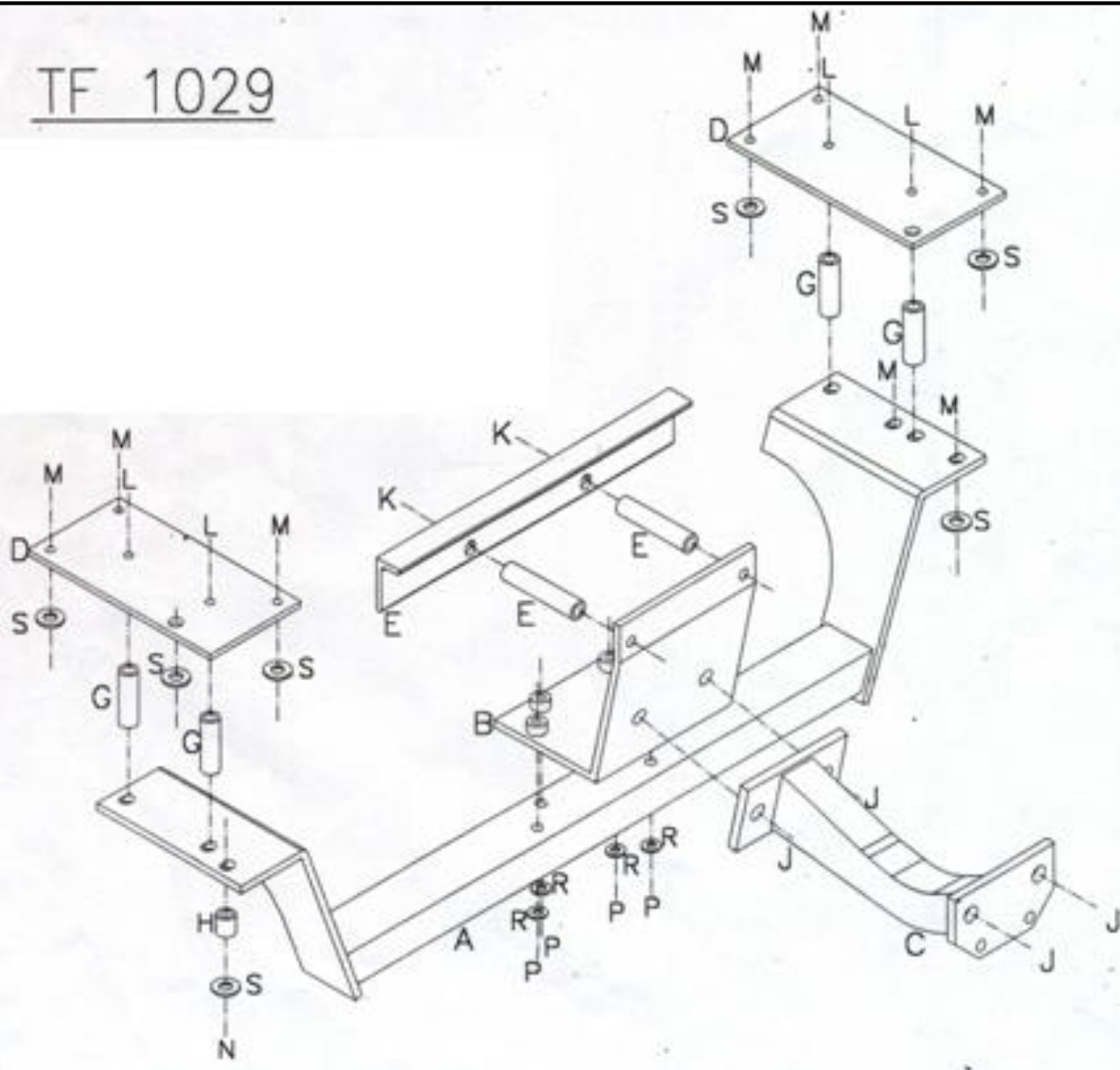

Tow with Trust