



Tow-Trust Towbars

Important: Please read General Notes overleaf before fitting

Issue 1

TF119 Ford Granada Scorpio Hatchback 1985-1994

Item	Qty	Description	Item	Qty	Description
A	1	Drop Plate Assembly	E	1	Main Bar
B	1	4 Hole Strap	F	2	M16 x 45 Bolts, Nuts & S/P Washers
C	1	Angle Bracket	G	14	M10 x 30 Bolts, Nuts & S/P Washers
D	2	Support Arms	H	4	10 x 30 Flat Washers
			I	2	10 x 40 Flat Washers

1. Remove the spare wheel, rear trim and rear bumper.
2. Using item **G** with item **I** inside the rear panel, bolt item **A** to the existing hole in the rear panel. Using the top holes in item **A** as jigs, drill two 11mm holes through into the boot. Place item **B** over these holes inside the boot and bolt using item **G**. Using the outer holes in item **B** as jigs, drill two 11mm holes through the rear panel. Using item **G** with item **H** under the heads, bolt item **B** into place. Using the three holes in item **A** as jigs, drill two holes through the rear panel and one through the rear face of the spare wheel well. Using item **G** with item **H** inside the rear panel and item **I** on the inside face of the spare wheel well bolt item **A** into place.
3. Remove the two forward bolts securing differential. Loosely bolt items **D** using the existing bolts. Using item **G** bolt item **C** to item **D**, (see sketch). Using item **G** bolt item **E** to item **A** and item **C**.
4. Using item **F** bolt the ball bracket and wiring plate (not supplied in this kit) to the mounting plate.
5. Fully tighten all nuts and bolts and ensure the towbar is rigid and secure. Replace spare wheel, trim and bumper.

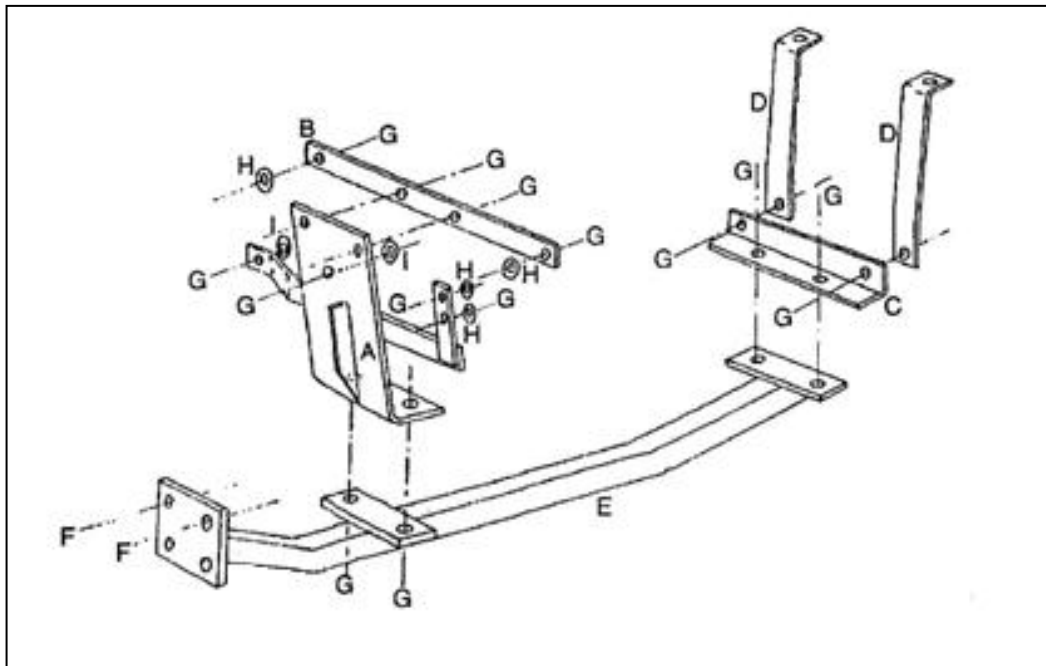

Note:

1. Recommended Torque Setting for M12 Grade 10.9 -139 Nm. (For other Torque Settings see notes overleaf.)
2. Nose load limits and vehicle manufacturer's trailer / caravan weight limits must be observed.