



Tow-Trust Towbars

Important: Please read General Notes overleaf before fitting

Issue 2

Type TF142 Ford Escort Hatchback October 92>

Item	Qty	Description	Item	Qty	Description
A	1	Crossmember	K	4	M16 x 50 Bolts, Nuts & Washers
B	1	Angle Bracket	L	5	M10 x 90 Bolts, Nuts & Washers
C	1	Extension Bar	L1	1	M10 x 100 Bolts, Nuts & Washers
D	1	L/H Clamp Plate	N	2	M10 x 30 Bolts, Nuts & Washers
E	1	R/H Clamp Plate	P	7	M8 x 50 Bolts 9 Nuts 7 Washers
F	1	Exhaust Strap	R	4	10 x 30 Flat Washers
G	5	19 x 57 Spacer Tubes	S	12	10 x 25 Flat Washers
H	1	17 x 58 Spacer Tube	T	6	8 x 25 Flat Washers
J	4	17 x 22 Spacer Tubes			

1. Remove the rear bumper (**note** on pre **S** registered vehicles there is no need for the fixings through the rear panel so there is no need to remove the bumper). Remove the boot floor covering.
2. Locate the blanks above each chassis member, three on the right hand side and two on the left, knock these blanks out and place item **G** down into the chassis, place item **D** and item **E** over the spacer tubes and pass item **L** down through the spacer tubes.
3. Remove the exhaust hanger or remove the rubber from the fixed exhaust hanger.
4. Using item **R** as packers, loosely bolt item **B** to the right hand chassis.
5. Position item **A** over the exhaust and using item **N** loosely bolt to item **B**, using the nuts and washers provided loosely bolt item **A** up to the chassis, using item **R** inside the open end of the chassis bolt to the rearmost item **L**.
6. Locate item **H** into the open end of the chassis and using item **L1** with item **R** bolt item **A** to the chassis.
7. Using the holes in item **D** and item **E** as jigs, drill four 9mm holes through the rear panel.
8. Using item **P** with item **T** against the rear panel and item **J** inside the boot bolt item **D** and item **E** into place.
9. Re-fit the exhaust either onto the existing fixed hanger or using the exhaust strap and bolts supplied.
10. Re-fit the bumper.
11. Using item **K** bolt item **C** to item **A** through the aperture in the bumper.
12. Using item **K** bolt the ball bracket and wiring plate (not supplied in this kit) to the mounting plate.
13. Fully tighten all nuts and bolts and ensure the towbar is rigid and secure.

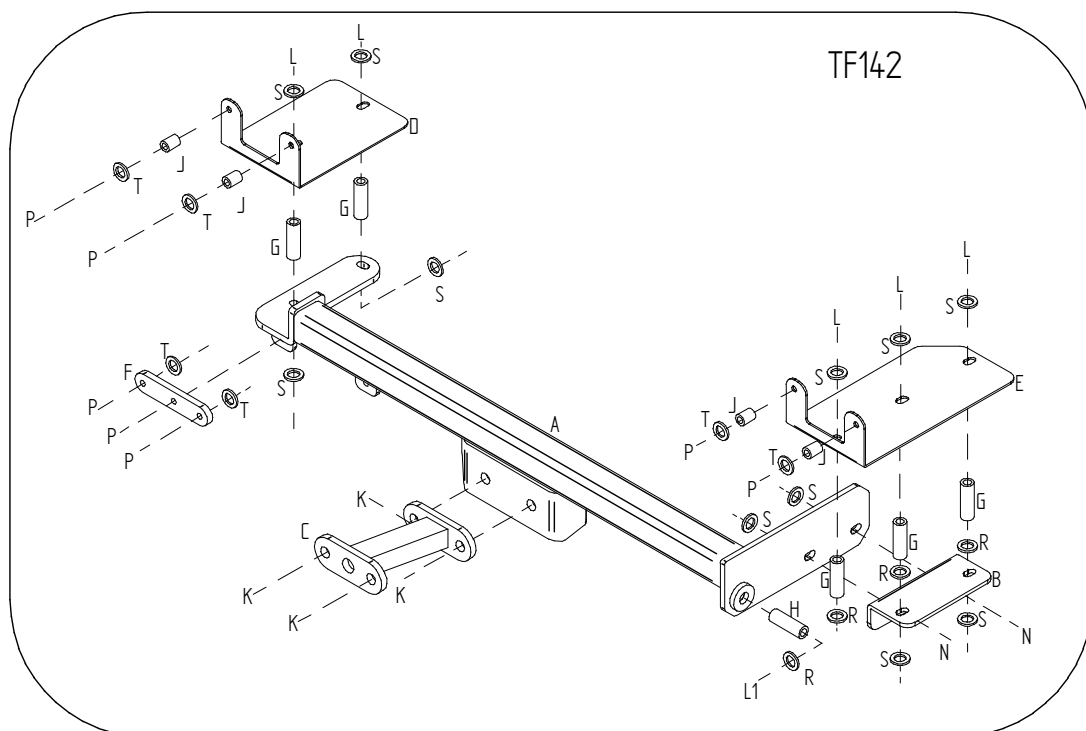

Note:

1. Recommended Torque Setting for M12 Grade 10.9 -139 Nm. (For other Torque Settings see notes overleaf.)
2. Nose load limits and vehicle manufacturer's trailer / caravan weight limits must be observed.