



Tow-Trust Towbars

Important: Please read General Notes overleaf before fitting

Issue 1

TF143B Ford Mondeo Saloon & Hatchback 1993 – 1996

Item	Qty	Description	Item	Qty	Description
A	1	Bracing Stay	E	2	M12 x 35 Bolts & S/P Washers
B	1	Long Crossmember	F	5	M10 x 30 Bolts, Nuts & S/P Washers
C	1	Short Crossmember	G	1	M10 x 35 Bolt & Nyloc Nut
D	2	M16 x 50 Bolts, Nuts & S/P Washer	H	5	M10 x 40 Flat Washers
			J	1	M10 x50 Washer

1. Remove boot carpet, spare wheel board cover and spare wheel.
2. Locate item **B** up against the raised section of the boot rear panel and mark off the holes for bolts item **E**. Drill out to 12mm taking care not to go too far through and into the foam impact beam.
3. Locate and remove (if fitted) the black oblong foam piece at the bottom of the bumper.
4. Slide item **A** up into the space left by removing the foam and line the two 12mm nuts up with the holes drilled in the rear panel.
5. Place item **B** up against the rear panel and using item **E** bolt item **A** and item **B** together, tighten these bolts partly to pull item **A** up towards the boot floor.
6. Drill the 2 outer holes in item **B** and fix using item **F** and item **H**.
7. Drill the hole at the forward end of item **A** at 10mm and sandwich item **C** between item **A** and the boot floor. Using item **G** and item **J** under the bolt head bolt item **A** and item **C** to the boot floor.
8. Square up item **C** against the boot floor and drill the two outer holes for bolts **F**, using item **H** under the bolt heads bolt item **C** to the boot floor.
9. Drill the remaining hole in item **A** and bolt to the floor using item **F** and item **H**.
10. Using item **D** bolt the ball bracket and wiring plate (not supplied in this kit) to the mounting plate.
11. Fully tighten all nuts and bolts and ensure the towbar is rigid and secure.
12. Refit spare wheel, cover and carpet.

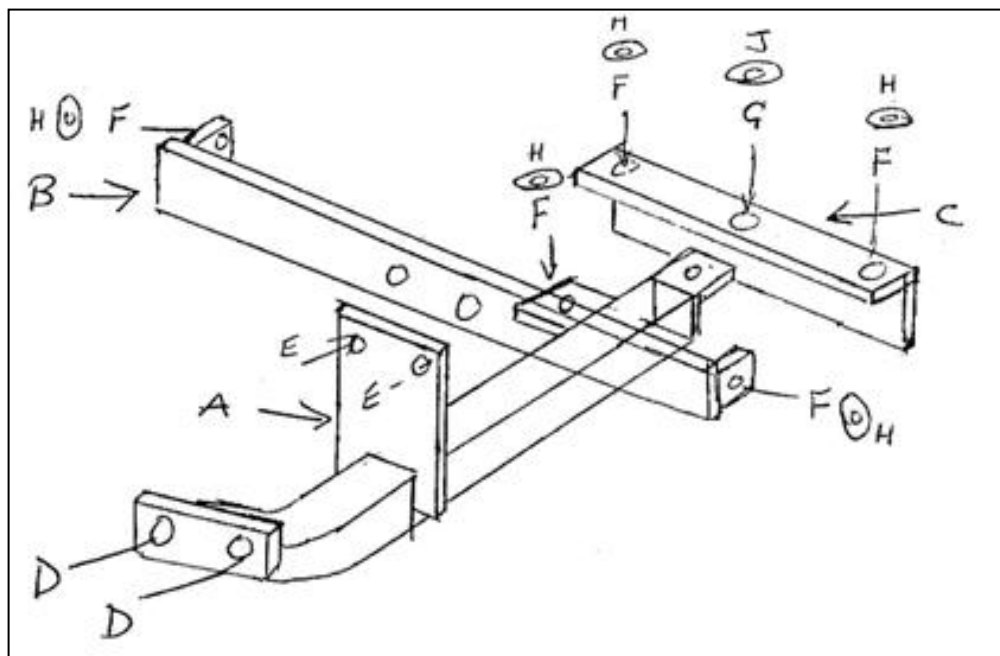

Note:

1. Recommended Torque Setting for M12 Grade 10.9 -139 Nm. (For other Torque Settings see notes overleaf.)
2. Nose load limits and vehicle manufacturer's trailer / caravan weight limits must be observed.