



# Tow-Trust Towbars

Important: Please read General Notes overleaf before fitting

Issue 5

## Type TF155B Ford Ranger / Mazda B2500 '99>

Item	Qty	Description	Item	Qty	Description
A	1	Towbar	H	2	M16 x 50 Bolts, Nuts & Washers
B	2	Side Arms	J	12	M12 x 35 x 1.5 Bolts, 6 Nuts & 8 Washers
C	2	Handed Bumper Brackets	J1	4	M12 x 40 x 1.5 Bolts, Nuts & S/P Washers
D	2	Clamp Plates (on wire)	K	2	M10 x 40 Bolts, 2 Washers
E	1	Coupling Spacer	L	2	M8 Nuts & Washers
F	2	Angle Brackets	M	4	Disc Spring Washers
G	1	Fog Light Bracket	N	2	10 x 25 Flat Washers
			P	2	8 x 25 Flat Washers
			R	1	M10 x 25 Bolt, Nut & Washer
			S	6	12 x 25 Flat washer

1. On the 4 WD only lower the spare wheel.
2. On the 2WD version remove the fog light then remove the bracket from the chassis. On the 4WD version disconnect the fog light then remove the under run bumper from its mounting brackets and remove brackets from the chassis.
3. Remove the vertical fixing from chassis to body found at the end of the chassis ready for Item **F**.
4. Using Item **J** with Item **M** bolt Items **B** into existing captive fixings on outside face of each chassis.
5. Using Item **J** with Item **S** bolt Item **F** to Item **B** sandwiching a further Item **S** in between the two so Item **F** fits level with the chassis.
6. Using Item **J** with Item **S** bolt Item **F** to vertical captive fixing in the body.
7. Locate Item **D** into open end of each chassis member and over the forward most hole in Item **B**, Using Item **K** with Item **N** bolt into place. (Note: on early versions this hole is not in the chassis in this case the side arms (Item **B**) are not bolted at this point).
8. Using Item **J** loosely bolt Item **A** to Item **B** (Upper three holes for the 2WD and lower three holes for the 4WD.)
9. **2WD version** – using existing bolts attach fog light to Item **G**, then using Item **R** bolt Item **G** to the lowest hole in Item **B**.
10. **4WD version** – using Item **J1** loosely bolt Item **C** to Item **B**. Using existing bolts, washers and Item **L** bolt the under run bumper to Item **C**. Reconnect the fog light.
11. Using Item **H** bolt the ball bracket and wiring plate (not supplied in this kit) to the mounting plate.
12. Fully tighten all nuts and bolts and ensure the towbar is rigid and secure.

**Note:** nose load limits and vehicle manufacturers' trailer / caravan weight limits must be observed.

# TF155B

2WD MODELS

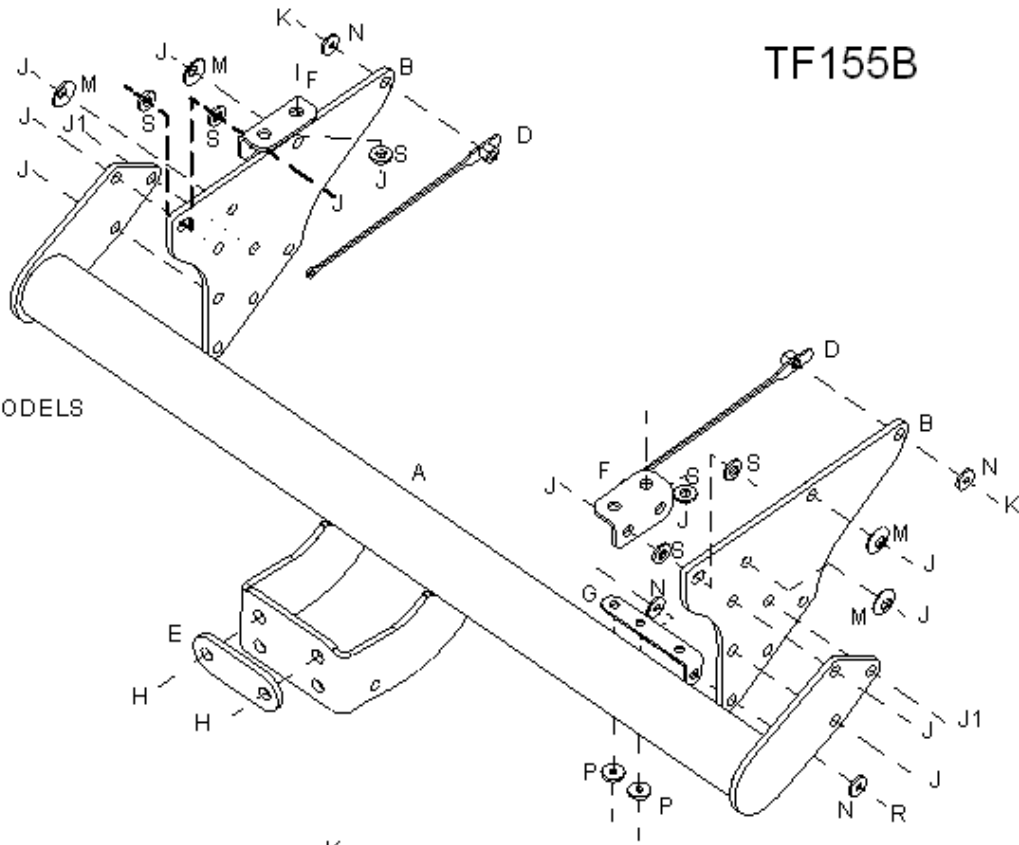

4WD MODELS

