

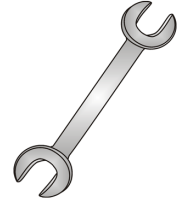

Tow-Trust Towbars

Important: Please read General Notes overleaf before fitting



Issue 3

TF167VK FORD C-MAX 2003> & FOCUS 2 HATCH 2005>

Item	Qty	Description	Item	Qty	Description
A	1	Crossmember	D	1	Flip Up Socket Plate
B	2	Handed Side Arms	E	2	M12 x 25 Bolts & S/P Washers
C	1	Detachable Housing	F	4	M12 x 40 Bolts, 2 Nuts & 4 S/P Washers
			G	4	M10 x 40 Bolts & S/P Washers
			H	4	10 x 40 Flat Washers
			J	4	12 x 25 Flat Washers
			K	2	M12 x 22 Bolts & S/P Washers

1. Remove the rear bumper. Two screws along lower edge, two tip screws each side, one nut under wheel arch liner each side, remove the reflectors from the top of the bumper, one screw behind each reflector. Pull the bumper out sideways at each tip then pull rearwards.
2. Cut a section from the lower edge of the bumper SEE SKETCH. If required trim to suit. **NOTE NEW C-MAX & GRAND C-MAX 2011>** Do not require bumper cut. **FOCUS 4 2011>** Cut under tray to suit Towbar. (under tray can be left off the vehicle and handed back to the customer)
3. Remove bumper beam. (This is not refitted with the Towbar.)
4. Place Item B into the open ends of each chassis and using Item G with Item H loosely bolt through existing holes.
5. Cut plastic tab off from the centre of the plastic rear panel.
6. Using Item F bolt Item A to Item B.
7. Using Item E with item J and Item K with Item J bolt item C and item D to Item A.
8. Fully tighten all nuts and bolts and ensure the Towbar is rigid and secure.
9. Replace bumper.

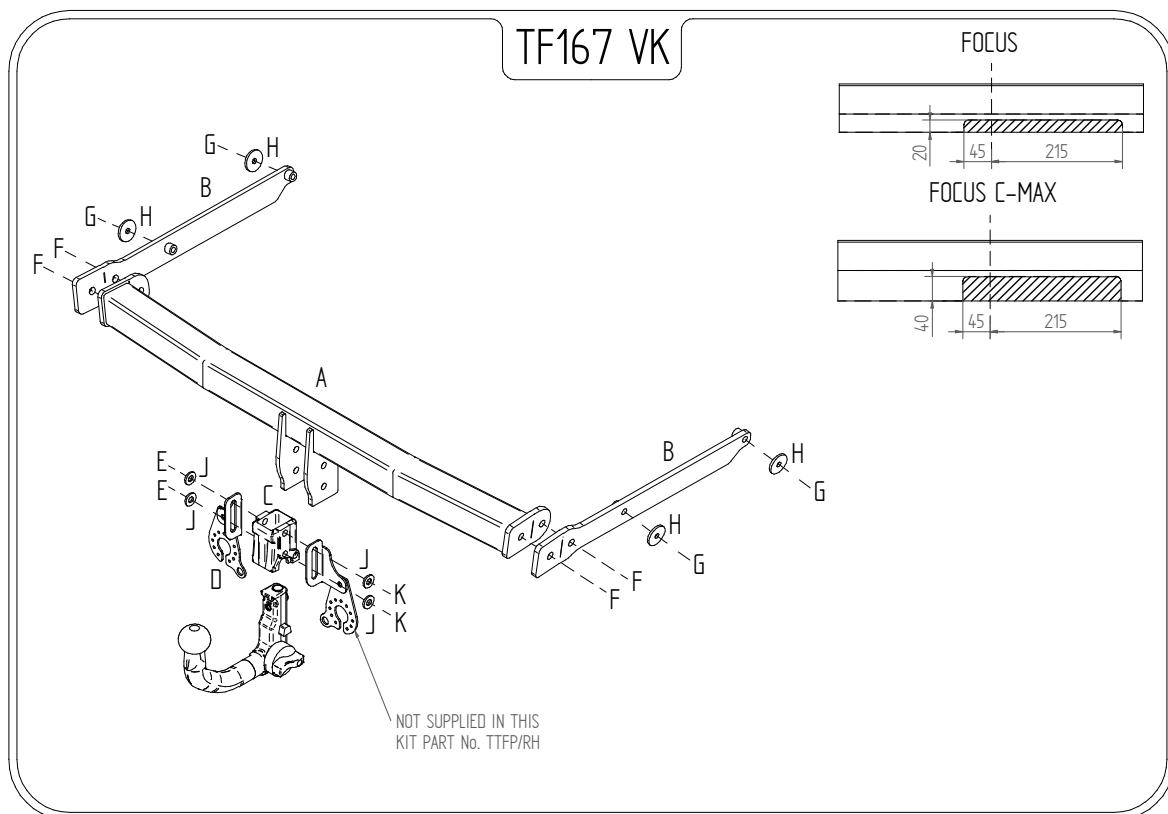

Note:

1. Recommended Torque Setting for M12 Grade 10.9 -139 Nm. (For other Torque Settings see notes overleaf.)
2. Nose load limits and vehicle manufacturers trailer / caravan weight limits must be observed.