



Tow-Trust Towbars

Important: Please read General Notes overleaf before fitting

Issue 2

TI955 ISUZU Rodeo Pick-up (Chrome Bumper) Inc. Max & D Max 2004> Inc. 2007 Models with Black Bumper

Item	Qty	Description	Item	Qty	Description
A	1	Crossmember	F	2	M16 x 50 Bolts, Nuts & Washers
B	1	Left Hand Side Arm	G	6	M12 x 40 Bolts, 4 Nyloc Nuts & 2 Washers
C	1	Right Hand Side Arm	H	6	M12 x 40 x 1.25 Bolts & Washers
D	1	Coupling Spacer	J	4	M14 x 45 Bolts & Washers
E	2	Captive Straps with M14 Nuts	K	6	12 x 25 Flat Washers
			L	4	14 x 27 Flat Washers
			M	6	M12 Bolt Caps

1. Unplug Fog and Number Plate lights.
2. Temporarily remove the rear bumper. Denver models – open up three holes each side in chrome bumper for ease of fitting.
3. Remove all the bolts securing the bumper arms to the bumper, (three on top under corner panels and two underneath).
4. Bend back the two location tabs on each bumper arm.
5. Remove the two captive nuts from the lower face of each chassis member and drill the existing holes out to 15mm.
6. Locate Item E inside the chassis and over the 15mm holes.
7. Using Item J with Item L loosely bolt Item B and Item C to each chassis.
8. Using Item H with Item K refit the bumper arms. Note: on D Max models drill a 13mm hole in each bumper side arm for upper bolt Item H. Note: on 2007 Models with Black Bumper trim bumper brackets (see sketch).
9. Using Item G bolt Item A to Item B and Item C. Item M (Bolt caps) are used to cover the outer heads of each bolt.
10. Refit bumper to bumper arms.
11. Align rear bumper and fully tighten all nuts and bolts.
12. Using item F with Item D bolt the ball bracket and wiring plate (not supplied in this kit) to the mounting plate.

Note: nose load limits and vehicle manufacturers trailer / caravan weight limits must be observed.

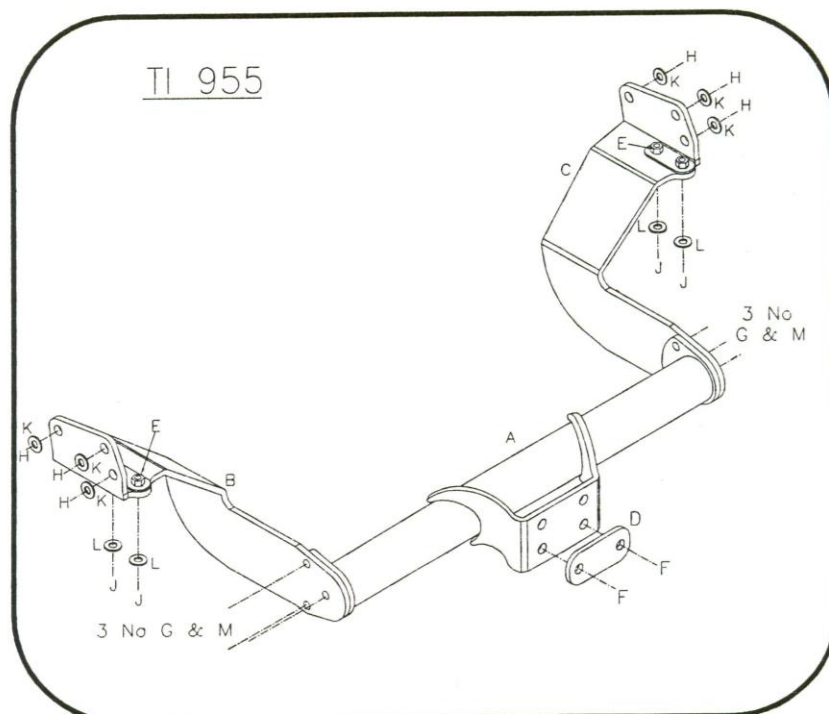

BLACK BUMPER MODEL, 2007 >

NEAR SIDE BUMPER
ARM SHOWN

