



# Tow-Trust Towbars

**Important:**

**Please Read General Notes (overleaf) Before Fitting:**

Issue 2

## Type TL244 Rover 200 3 Door / 5 Door Hatchback 95>

Item	Qty	Description	Item	Qty	Description
A	1	Crossmember	F	4	M10 x 30 Bolts & Washers only
B	2	Handed Side Arms	G	4	M12 x 30 Bolts 2 Nuts & 4 Washers
C	1	Clamp Plate	H	1	M12 x 40 Bolt Nut & Washer
D	1	19 x 14 Spacer Tubes	I	2	10 x 40 Washers
E	2	M16 x 40 Bolts Nuts & Washers	J	2	10 x 30 Washers

1. Remove the rear bumper (one bolt on the lower edge, tip and mudflap screws and five plastic clips on the top edge) remove the covers from the ends of each chassis member, these are no longer required.
2. Locate item **B** into the end of each chassis member and using item **F** with item **I** (front bolts) and item **J** (rear bolts) under each bolt head, loosely bolt the side arms into place (for easy access remove the heat shield bolt) replace the existing bolts from the chassis covers.
3. Using item **G** loosely bolt item **A** to item **B**.
4. Using item **H** with item **D** and item **C** under the bolt head item **A** to the towing eye.
5. Using item **E** bolt the ball bracket and wiring plate (not supplied in this kit) to the mounting plate.
6. Fully tighten all nuts and bolts and ensure the towbar is rigid and secure, replace the heat shield bolt.
7. Locate the marked out mouse hole on the inside face of the bumper and neatly cut out and replace bumper.

**Note:** nose load limits and vehicle manufacturers trailer / caravan weight limits must be observed.

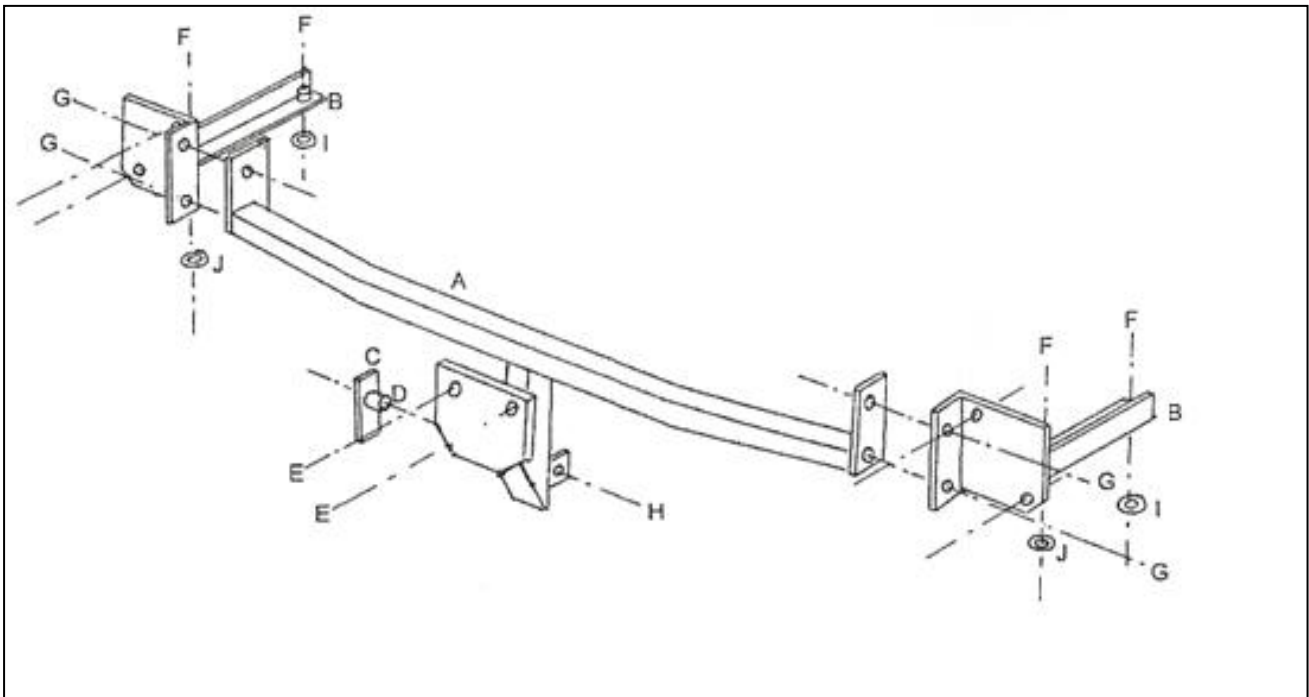

### Additional Fitting Instructions for Rover 25

1. Remove the bumper, 5 plastic screws on the top edge, 1 bolt at each wingtip, 1 bolt underneath. Remove the light clusters (1 x 10mm bolt).
2. Remove the foam insert, this is no longer required.
3. Remove and discard the crush caps.
4. Fit the towbar as per the above instructions.
5. Cut out section of bumper 55mm wide x 80mm deep, (See sketch at side,) and refit.

