



Tow-Trust Towbars

Important: Please read General Notes overleaf before fitting

Issue 1

TL249VK Range Rover 2002>

Item	Qty	Description	Item	Qty	Description
A	1	Towbar	P	4	M8 x 30 Bolts, Nuts & S/P Washers
B	2	Bent Side Arms	R	4	M12 x 35 Bolts & S/P Washers
C	2	Handed Side Arms	S	2	M14 x 1.5 x 220 Bolts & S/P Washers
D	2	Drop Plates	T	2	M14 x 1.5 x 160 Bolts & S/P Washers
E	2	Detachable Neck	W	4	12 x 25 Flat Washers
M	4	17 x 12 Exhaust Spacers	X	4	14 x 27 Flat Washers
M1	2	Exhaust Brackets for Models 2006 > only	Y	4	8 x 25 Flat Washers
				4	M12 Bolt Caps

1. Remove boot floor covering and rear trim.
2. Remove the rear bumper. (Four nuts each side inside the boot on the rear panel.) After removal of boot floor trims remove mud flaps if fitted, remove tip screws and clips.
3. Remove the rearmost left hand and right hand exhaust brackets.
4. Remove the towing eyes. (These will not be fitted with the towbar.)
5. Locate item **D** onto the bumper bolts and refit the bumper.
6. Using item **R** with item **W** loosely bolt item **A** to item **D**.
7. Place item **X** and item **B** onto the shank of item **S**, pass up through the holes in item **A** and locate item **C** onto the top face of item **A** loosely bolt into place into the existing rearmost threaded holes.
8. Using item **T** with item **X** loosely bolt the assembly to the existing forward threaded holes.
9. Using item **P** with item **Y** and item **M** if required refit the exhaust brackets to the side arms (item **C**).
NOTE: These spacers are only used if the exhaust has to be lowered.
10. Fully tighten all nuts and bolts and ensure the towbar is rigid and secure.

Note:

1. Recommended Torque Setting for M12 Grade 10.9 -139 Nm. (For other Torque Settings see notes overleaf.)
2. Nose load limits and vehicle manufacturer's trailer / caravan weight limits must be observed.

TL249VK

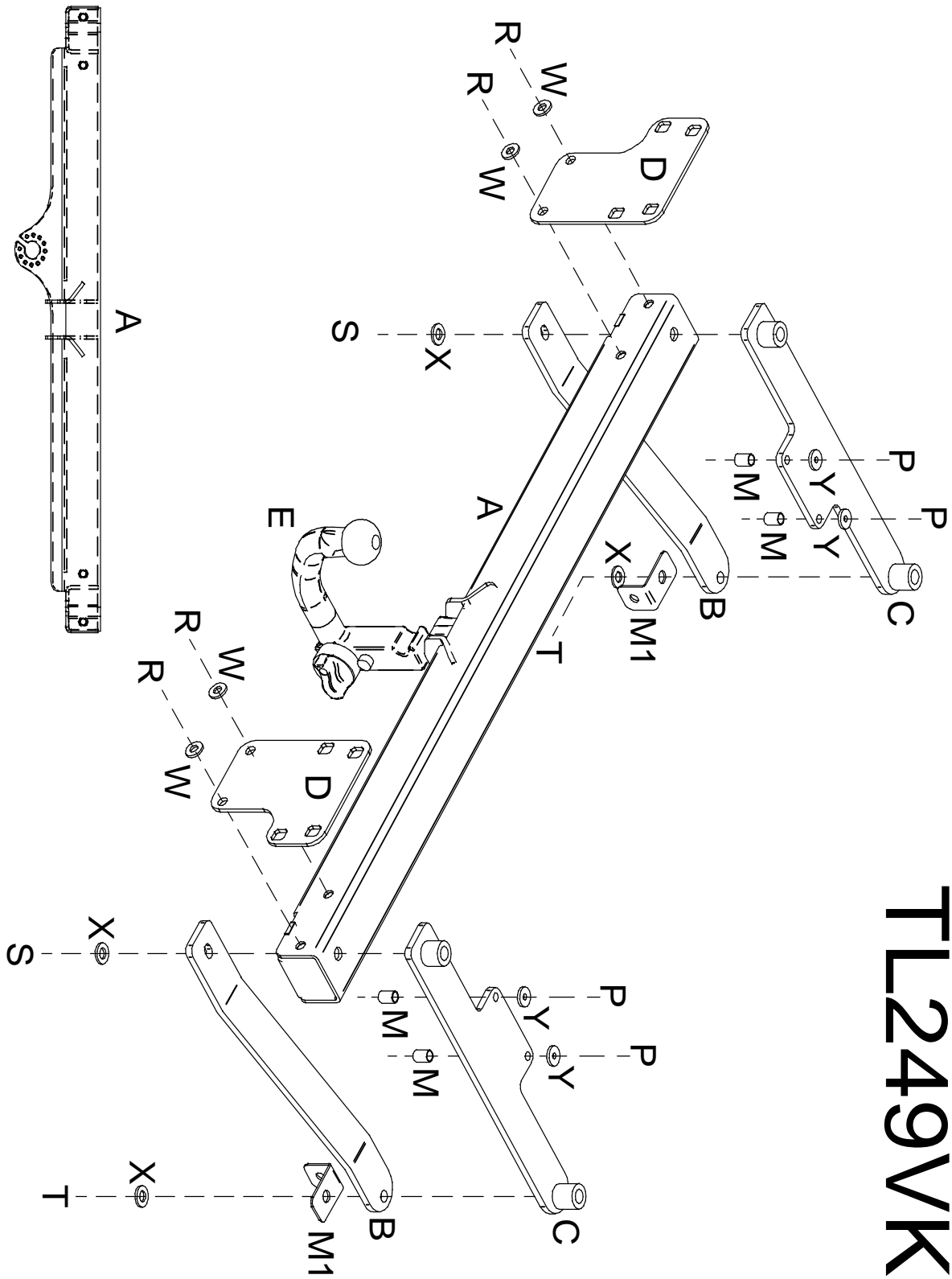

Tow with Trust