



# Tow-Trust Towbars

**Important: Please read General Notes overleaf before fitting**

Issue 2

## Type TM868A Mercedes Sprinter Van 95-2006 (3000MM Wheelbase without Step/ 3550/4025MM Wheelbase with Step)

Item	Qty	Description	Item	Qty	Description
<b>A</b>	1	Crossmember	<b>E</b>	2	M16 x 50 Bolts, Nuts & S/P Washers
<b>B</b>	2	Handed Side Plates	<b>F</b>	8	M12 x 100 Bolts, Nuts & S/P Washers
<b>C</b>	2	Angle Brackets	<b>G</b>	8	M12 x 45 Bolts, Nuts & S/P Washers
<b>D</b>	2	Spacers	<b>H</b>	4	M10 x 35 Bolts & S/P Washers
			<b>J</b>	2	12 x 40 Flat Washers
			<b>K</b>	12	12 x 25 Flat Washers
			<b>L</b>	4	10 x 25 Flat Washers

**1. Models with no step fitted (208D).**

Remove the towing eye from the chassis and the rear panel.

**1A. Models with step fitted (308D & 312D).**

Remove the two bolts securing the step to the chassis and the four bolts securing the step to the rear panel.

2. Locate the four existing holes in each chassis and using Item **F** with Item **K** loosely bolt Item **B** to the inside face. (On models with no step fitted place Item **J** between each side arm and the chassis.)

3. Using Item **G** loosely bolt Item **A** to Item **B**.

4. Using Item **G** with Item **K** loosely bolt Item **C** and Item **D** to Item **A**. (See sketch for relevant crossmember position.)

5. Using Item **H** with Item **L** bolt Item **C** to the existing captive nuts in each chassis member. Note 308D and 312D models with steps, the bracket is trapped between the angle bracket (Item **C**) and the chassis.

6. Using item **E** bolt the ball bracket and wiring plate (not supplied in this kit) to the mounting plate.

7. Fully tighten all nuts and bolts and ensure the towbar is rigid and secure.

**Note:** nose load limits and vehicle manufactures trailer / caravan weight limits must be observed.

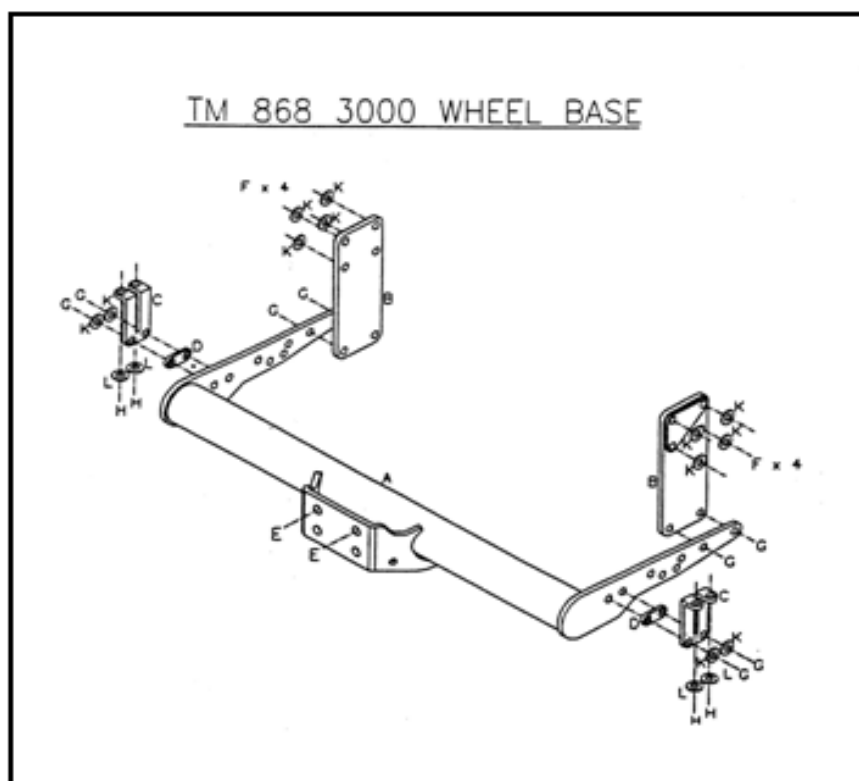

TM 868 3550/4025 WHEEL BASE

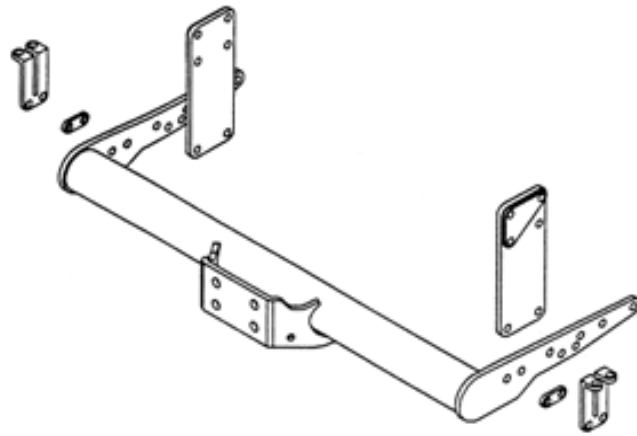

TM 868 3000 WHEEL BASE

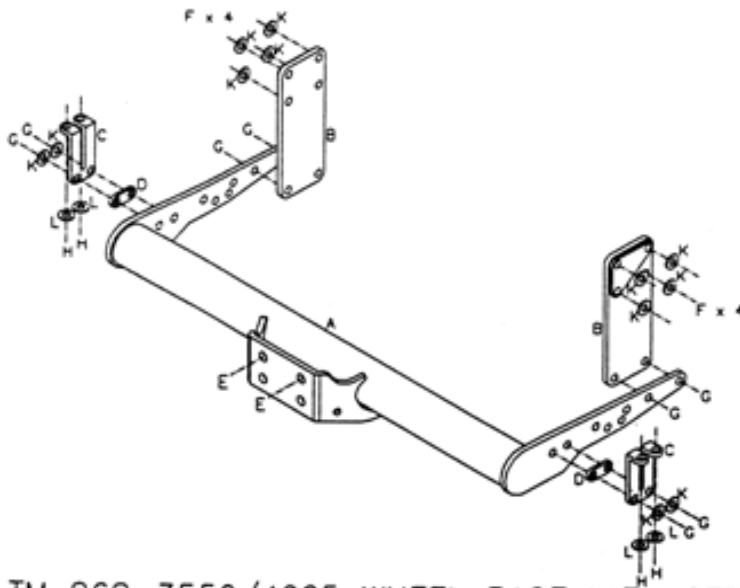

TM 868 3550/4025 WHEEL BASE WITH STEP

