



Tow-Trust Towbars

Important: Please read General Notes overleaf before fitting

Issue 2

TM874 VK Mercedes C class Saloon (W203) 2000>

Item	Qty	Description	Item	Qty	Description
A	1	Crossmember	J	2	M12 x 22 Bolts & S/P Washers
B	1	L/H Side Arm	K	1	M8 Nut & S/P Washers
C	1	R/H Side Arm	L	4	10 x 40 Flat Washers
D	1	Detachable Housing	M	6	10 x 30 Flat Washers
E	2	M12 x 25 Bolts & S/P Washers	N	10	10 x 25 Flat Washers
F	2	M10 x 65 Bolts Nuts & S/P Washers	P	1	8 x 25 Flat Washers
G	10	M10 x 45 Bolts, 6 Nuts & 10 S/P Washers	R	8	6 x 20 Flat Washers
H	4	M6 x 25 Bolts Nuts & S/P Washers	S	4	12 x 25 Flat Washers
			T	1	Flip Up Socket Plate

IMPORTANT: IT IS ADVISABLE TO USE A SEALANT ON MATING FACES, AND AROUND ANY MOUNTING POINTS ON REAR PANEL TO PREVENT ANY WATER DAMAGE TO CHASSIS OR BOOT.

1. From inside the boot, remove the trim panels.
2. Remove the rear bumper and rearmost exhaust hanger (three nuts on the rear panel each side also two small nuts each side, one vertical screw inside the rear quarter panels, two clips and a vertical screw at each bumper tip).
3. Remove the bumper beam.
4. Remove the next exhaust hanger.
5. Remove the heat shield, locate and remove the rubber grommets from each chassis member.
6. Locate item **B** and item **C** into each chassis member and using item **G** with item **L** bolt and fully tighten into place (four hole plates should be up against the rear panel).
7. Re-fit the heat shield and forward exhaust hanger. (**NOTE:** SOME CLK EXHAUST HANGERS REQUIRE A 14mm HOLE TO BE DRILLED, SEE SKETCH).
8. Using item **E** with item **S** and item **J** with item **S** bolt item **D** and **T** to item **A** and fully tighten.
9. Using item **H** with item **R** bolt the bumper to item **A**, centralise and tighten bolts.
10. Re-fit the bumper assembly onto the sliders and the studs on the upper edge of the bumper; bolt using the existing small nuts.
11. Using item **F** item **G** item **N** and item **M** bolt item **A** to item **B** and item **C** also through the rear panel. Ensure the bumper is correctly in place and fully tighten all nuts and bolts.
12. Re-fit rearmost exhaust hanger onto the studs provided on the towbar.

Note:

1. Recommended Torque Setting for M12 Grade 10.9 -139 Nm. (For other Torque Settings see notes overleaf.)
2. Nose load limits and vehicle manufacturer's trailer / caravan weight limits must be observed.

REAR VIEW

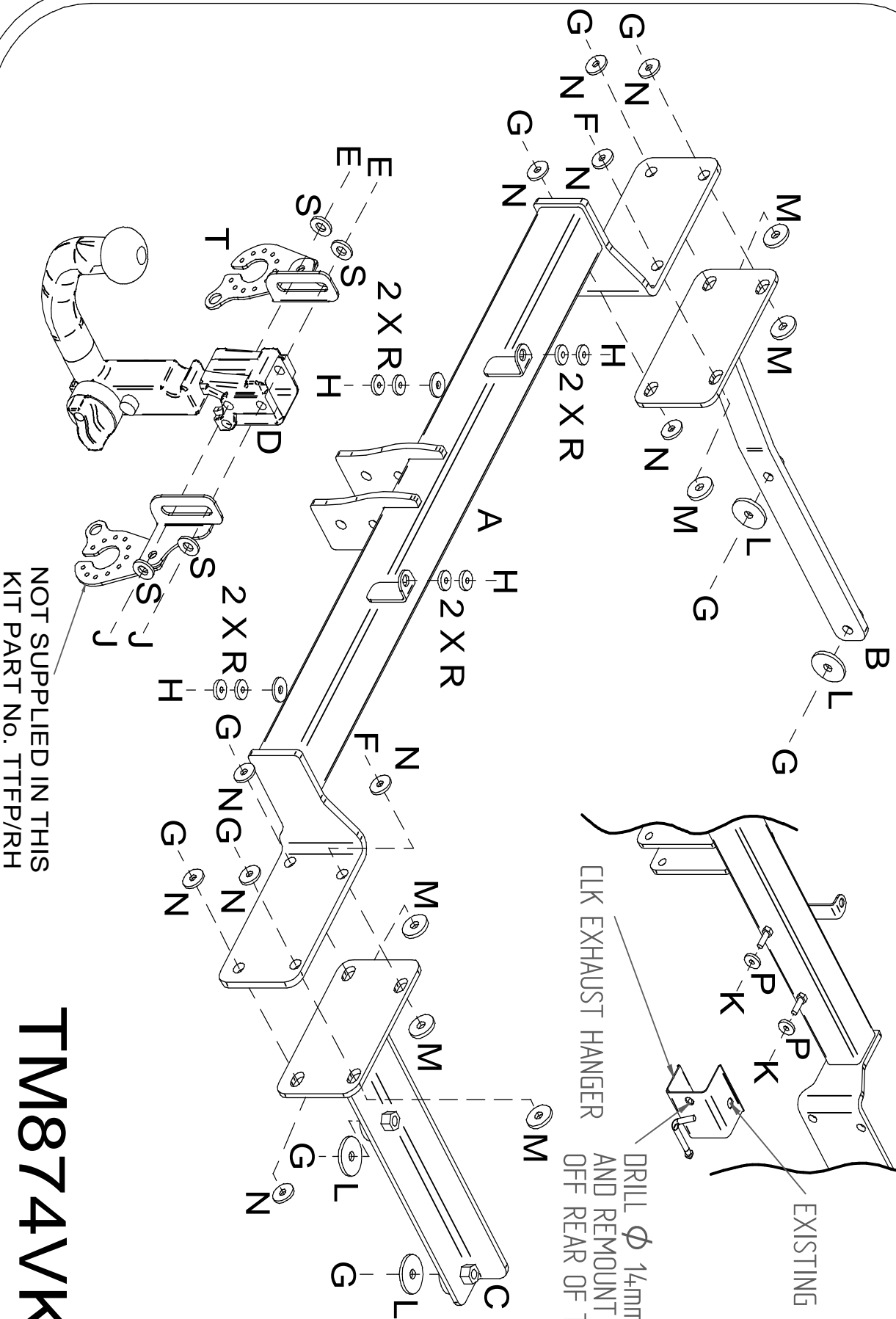
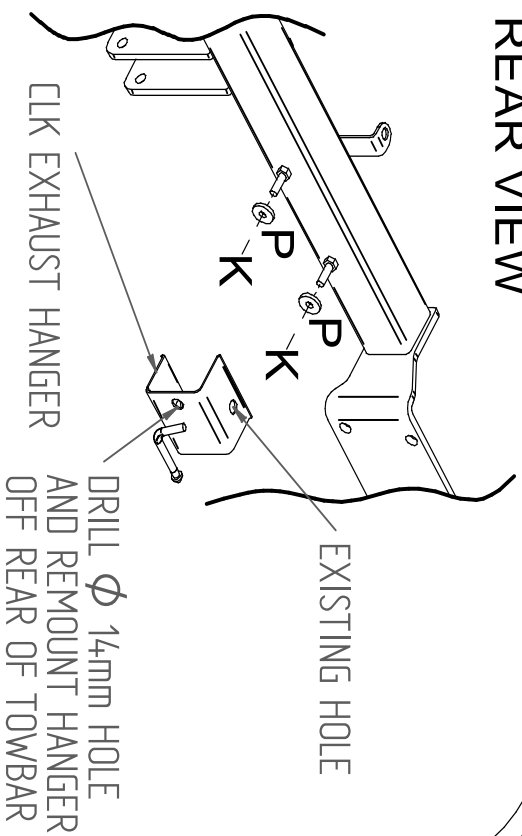

NOT SUPPLIED IN THIS
KIT PART NO. TTFP/RH

TM874VK