



# Tow-Trust Towbars

Important: Please read General Notes overleaf before fitting

Issue 5

## TMZ2 MAZDA 6 HATCHBACK 2002>

Item	Qty	Description	Item	Qty	Description
A	1	Crossmember	G	2	M16 x 50 Bolts, Nuts & S/P Washers
B	1	L/H Side Arm	H	2	M12 x 100 Bolts, Nut & S/P Washers
C	1	R/H Side Arm	J	2	M12 x 110 Bolts, Nuts & S/P Washers
D	4	Clamp Plates	K	4	M12 x 40 Bolts, 2 Nuts & 4 S/P Washers
E	2	19mm x 59mm Spacer Bushes	L	4	12 x 40 Flat Washers
F	2	19mm x 64mm Spacer Bushes	M	6	12 x 25 Flat Washers
			N	2	Rivets

**NOTE: THERE ARE TWO SETS OF HOLES IN THE SIDE ARMS THESE ARE SO YOU CAN FIT THE TOWBAR AS SNUG AS POSSIBLE TO THE BACK PANEL. (DUE TO MODEL VARIANTS).**

1. Remove rear bumper. One tip fixing, two fixings at bottom of wheel arch, two fixings along lower edge, two fixings under rear light.
2. Disconnect rear parking sensors if fitted.
3. Remove bumper beam. (This is not refitted with the towbar) (Replace existing bolts)
4. Mark out and cut open the ends of each chassis (see sketch). Note: It is recommended to paint the end of each chassis after cutting.
5. Lower the exhaust. Note: Support the exhaust to prevent damage.
6. Drill out the rearmost rivet securing the heat shield.
7. Locate dimples at rear of boot and existing forward holes and enlarge to 20mm.
8. Locate Item **B** and Item **C** into the open end of each chassis.
9. Place Item **E** (rear holes) and Item **F** (forward holes) down into each chassis and using Item **H** (rear holes) and Item **J** (forward holes) with Item **D** inside the boot loosely bolt each side arm into place.
10. Using Item **K** with Item **M** bolt Item **A** to Item **B** and Item **C**. Push Item **A** as close to the rear panel as possible.
11. Fully tighten all nuts and bolts and ensure the towbar is rigid and secure.
12. Using Item **N** Rivet the heat shield back into place through original hole.
13. Replace exhaust.
14. Cut a small section 20mm x 155mm in the lower edge of the bumper.
15. Replace bumper.
16. Using Item **G** bolt the ball bracket and wiring plate (not supplied in this kit) to the mounting plate.

**Note:** nose load limits and vehicle manufacturers' trailer / caravan weight limits must be observed.

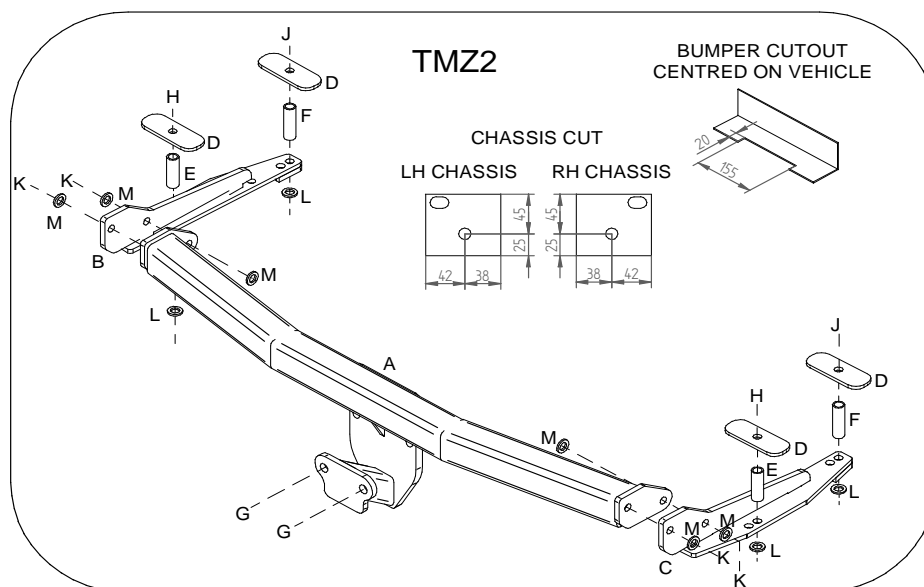

**Note:**

1. Recommended Torque Setting for M12 Grade 10.9 -139 Nm. (For other Torque Settings see notes overleaf.)
2. Nose load limits and vehicle manufacturer's trailer / caravan weight limits must be observed.