



Tow-Trust Towbars

Important: Please read General Notes overleaf before fitting

Issue 2

TN811A Nissan Serina '93>

Item	Qty	Description	Item	Qty	Description
A	1	Crossmember	F	2	M16 x 50 Bolts, Nuts & S/P Washers
B	1	L/H Side Arm	G	4	M12 x 30 Bolts, Nuts & S/P Washers
C	1	R/H Side Arm	H	28	M10x 35x1.25 Bolts, 10 Nuts 28 S/P Washers
D	2	Handed Brackets	J	20	10 x 25 Flat Washers
E	2	Handed Angle Brackets	K	4	10 x 30 Flat Washers
			L	4	12 x 25 Flat Washers

1. Locate the eight existing threaded holes in the rear crossmember of the vehicle. Using item H with item J loosely bolt item A into place.
2. Using item H with item J loosely bolt item D to the existing threaded holes in the lower face of each chassis member.
3. Using item H with item K loosely bolt item E to item D.
4. Using item H with item J loosely bolt item E to the inside face of each chassis.
5. Using item G with item L loosely bolt item B and item C to item A.
6. Using item H with item J loosely bolt item B and item C to the forward crossmember and to item D. Note on some models the crossmember is not in place so bolt item B and item C directly to item D.
7. Using item F bolt the ball bracket and wiring plate (not supplied in this kit) to the mounting plate.
8. Fully tighten all nuts and bolts and ensure the towbar is rigid and secure.

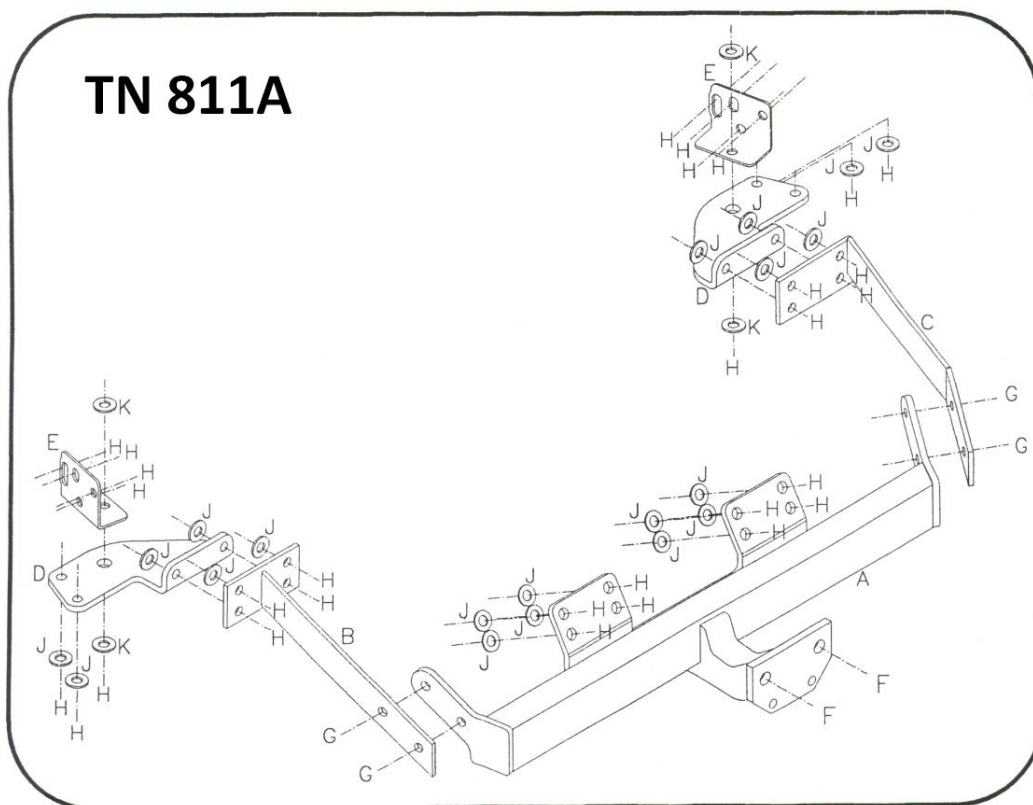

Note:

1. Recommended Torque Setting for M12 Grade 10.9 -139 Nm. (For other Torque Settings see notes overleaf.)
2. Nose load limits and vehicle manufacturer's trailer / caravan weight limits must be observed.