



Tow-Trust Towbars

Important: Please read General Notes overleaf before fitting

Issue 1

TN835B Nissan Navara low line 2WD

Item	Qty	Description	Item	Qty	Description
A	1	Crossmember	J	2	M16 x 50 Bolts, Nuts & S/P Washers
B	2	Side Arms	K	2	M12 x 100 Bolts, Nuts & S/P Washers
C	2	Handed Side Arm Extensions	L	14	M12 x 45 Bolts 12 Nuts & 14 S/P Washers
D	2	Handed Angle Brackets	M	6	M12 x 35 Bolts 4 Nuts & 6 S/P Washers
E	2	Straps with Captive Bolts	N	2	M10 Nuts & S/P Washers
F	2	19 x 52 Spacer Bushes	P	28	12 x 25 Flat Washers
G	1	Coupling Spacer	R	2	10 x 25 Flat Washers
H	2	8mm Spacer Plates	S	2	12 x 40 Flat Washers

1. Lower the spare wheel. **Note** models without rear bumpers remove the six bolts securing the rear panel to allow item **C** to be located into each chassis.
2. Remove the bolts securing the bumper to the bumper arms and the bumper side arms to each chassis (the existing captive bolt straps are no longer required.)
3. Locate item **E** inside each chassis and place the bolt through existing hole using item **N** and item **R** loosely bolt item **D** into place (see sketch).
4. Locate item **C** into each chassis and using item **L** with item **P** loosely bolt at forward mounting points.
5. Place item **B** against each chassis with the existing bumper arms on the outer face, loosely bolt into position using item **L** with item **P**.
6. Using item **K** with item **P**, item **S** and item **F** secure at the remaining point.
7. Using item **M** bolt item **A** to item **B** in any of the three mounting positions.
8. Refit the bumper.
9. Using item **J** with item **G** bolt the ball bracket and wiring plate (not supplied in this kit) to the mounting plate.
10. Fully tighten all nuts and bolts and ensure the towbar is rigid and secure.

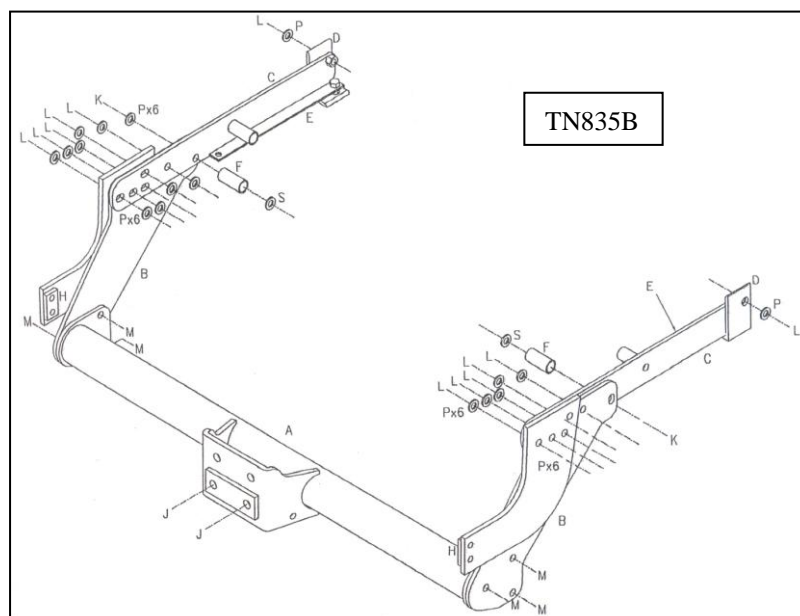

Note:

1. Recommended Torque Setting for M12 Grade 10.9 -139 Nm. (For other Torque Settings see notes overleaf.)
2. Nose load limits and vehicle manufacturer's trailer / caravan weight limits must be observed.