



Tow-Trust Towbars

Important: Please read General Notes overleaf before fitting

Issue 2

TN 845B Nissan Navara August 2005>

Item	Qty	Description	Item	Qty	Description
A	1	Crossmember	E	2	M16 x 50 Bolts, Nuts & S/P Washers
B	1	L/H Side Arm	F	2	M12 x 85 Grade 10.9 Bolts & Nyloc Nuts
C	1	R/H Side Arm	G	4	M12 x 35 Bolts, 2 Nuts & 4 S/P Washers
D	1	Extension Bar	H	10	M12 x 1.25 x 35 Grade 10.9 Bolts & 12 S/P Washers
			J	10	12 x 25 Flat Washers
			K	4	Disc Spring Washers
			L	1	L/H Socket Plate

- Using Item H with Item J loosely bolt Item B and Item C to the three existing captive nuts each side in the lower face of each chassis member.
- Using Item G with Item J loosely bolt Item A to Item B and Item C.
- Using Item H with Item J bolt Item A to the two existing captive nuts on the inside face of each chassis member.
- Using Item F with Item K bolt Item D and Item L to Item A.
- Using Item E bolt the ball bracket and wiring plate (not supplied in this kit) to the mounting plate.
- Fully tighten all nuts and bolts and ensure the towbar is rigid and secure.

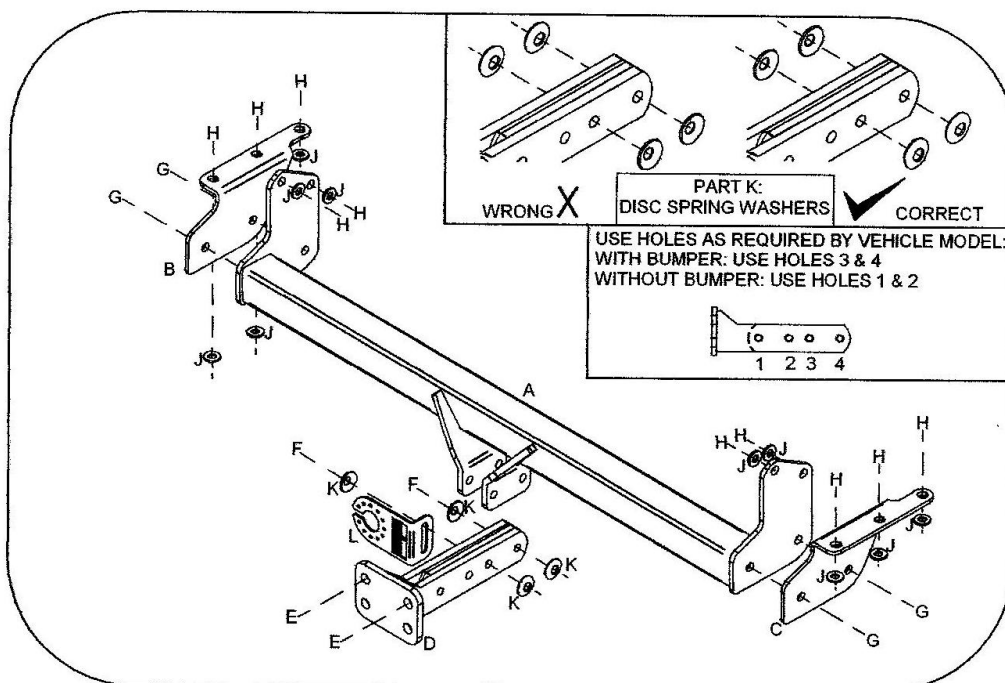

Note:

- Recommended Torque Setting for M12 Grade 10.9 -139 Nm. (For other Torque Settings see notes overleaf.)
- Nose load limits and vehicle manufacturer's trailer / caravan weight limits must be observed.