



# Tow-Trust Towbars

Important: Please read General Notes overleaf before fitting

Issue 6

## TP435 Peugeot 407 Saloon/Coupe 2004> Citroen C5 (X73) 2008>

Item	Qty	Description	Item	Qty	Description
A	1	Crossmember	E	2	M16 x 50 Bolts Nuts & Washers
B	1	Left Hand Side Arm	F	2	M12 x 40 Bolts, Nuts & Washers
C	1	Right Hand Side Arm	G	2	M10 x 40 Bolts & Washers
D	1	Extension Bar	H	6	M8 x 30 Bolts & Washers
			J	2	M8 x 40 Bolts & Washers
			K	2	M12 x 85 Grade 10.9 Bolts & Nyloc Nuts
			L	6	12 x 25 Flat Washers
			M	2	10 x 25 Flat Washers
			N	8	8 x 25 Flat Washers

- Temporarily disconnect the rear light clusters and remove. (Unclip the inner boot lining to gain access to the fixings.)
- Disconnect the number plate light and remove number plate.
- Remove the rear bumper. (**PEUGEOT 407**) Five fixings along bottom edge, one fixing on the lower central bumper support, two fixings in each light cluster area, two fixings under each wheel arch, two fixings on the left and right hand upper edge of the bumper.  
(**CITROEN C5**) Five fixings on the bottom edge, one fixing in each light cluster area, three fixings around wheel arch, and one fixing behind wheel arch liner.
- Remove the eight fixings securing the bumper beam. (This is not refitted with the towbar.)
- Remove all mastic from around towbar fixing points.
- Using Item **H** with Item **N** loosely bolt Item **A** to the rear panel.
- Locate the existing threaded holes in each chassis (these are covered with tape) and using Item **G** with Item **M** loosely bolt Item **B** and Item **C** into place.
- Using Item **F** with Item **L** loosely bolt Item **C** to Item **A**.
- Using Item **J** with Item **N** loosely bolt Item **B** to Item **A**.
- Fully tighten all nuts and bolts and ensure the towbar is rigid and secure.
- Refit bumper, number plate and light clusters.
- Using Item **K** with Item **L** bolt Item **D** to Item **A**
- Using Item **E** bolt the ball bracket and wiring plate (not supplied in this kit) to the mounting plate.

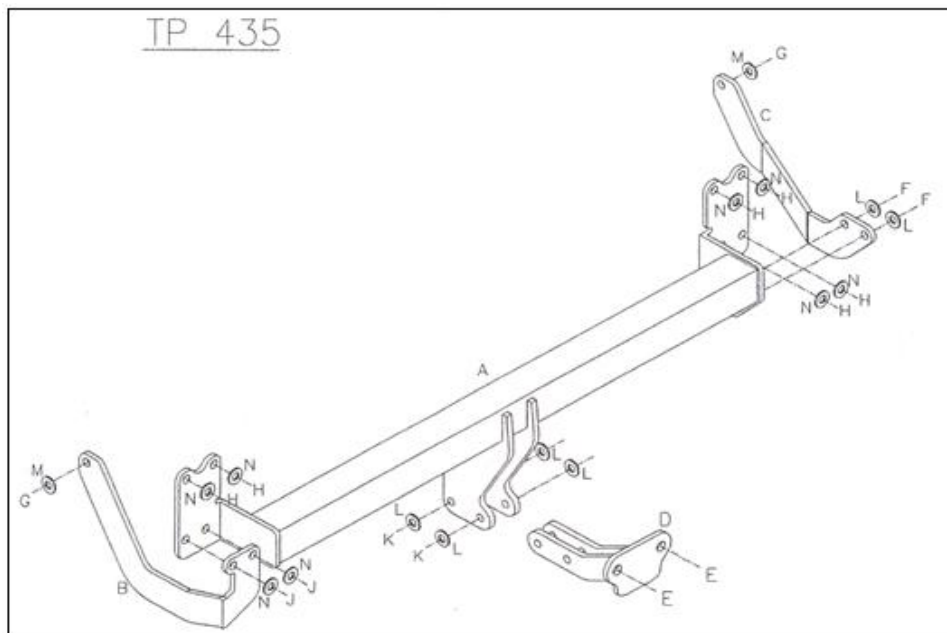

### Note:

- Recommended Torque Setting for M12 Grade 10.9 -139 Nm. (For other Torque Settings see notes overleaf.)
- Nose load limits and vehicle manufacturers trailer / caravan weight limits must be observed