



Tow-Trust Towbars

Important: Please read General Notes overleaf before fitting

Issue 1

TP9VK Peugeot 508 SW 2011>

Item	Qty	Description	Item	Qty	Description
A	1	Crossmember	E	2	M12 x 25 Bolts & S/P Washers
B	1	Left Hand Side Arm	F	2	M12 x 40 Bolts, Nuts & S/P Washers
C	1	Right Hand Side Arm	G	2	M10 x 30 Bolts & S/P Washers
D	1	Detachable Housing	H	6	M8 x 30 Bolts & S/P Washers
			J	2	M8 x 40 Bolts & S/P Washers
			K	2	M12 x 22 Bolts & S/P Washers
			L	6	12 x 25 Flat Washers
			M	2	10 x 25 Flat Washers
			N	8	8 x 25 Flat Washers
			P	1	Flip Up Socket Plate

BUMPER REMOVAL:

Remove the rear light clusters, one fixing behind each interior side trim.

Remove the bumper fixing found behind each light cluster, two fixings each side around each wheel arch liner, one fixing each side behind each arch liner and one tip fixing each side. Disconnect reversing sensor plug and remove remaining three fixings along the lower edge.

Pull each bumper tip outwards to release then rearward.

TOWBAR INSTALATION:

1. Temporarily remove the black plastic bumper support located above the rear crash beam.
2. Remove the eight fixings securing the bumper beam. (This is not refitted with the Towbar.)
3. Using Item H with Item N loosely bolt Item A to the rear panel.
4. Locate the existing threaded holes in each chassis (these are covered with tape) and using Item G with Item M loosely bolt Item B and Item C into place.
5. Using Item F with Item L loosely bolt Item C to Item A.
6. Using Item J with Item N loosely bolt Item B to Item A and the rear panel.
7. Using Item K with Item L and Item E with Item L bolt Item D and Item P to Item A.
8. Fully tighten all nuts and bolts and ensure the Towbar is rigid and secure.
9. Reconnect reversing sensors, refit bumper and light clusters.

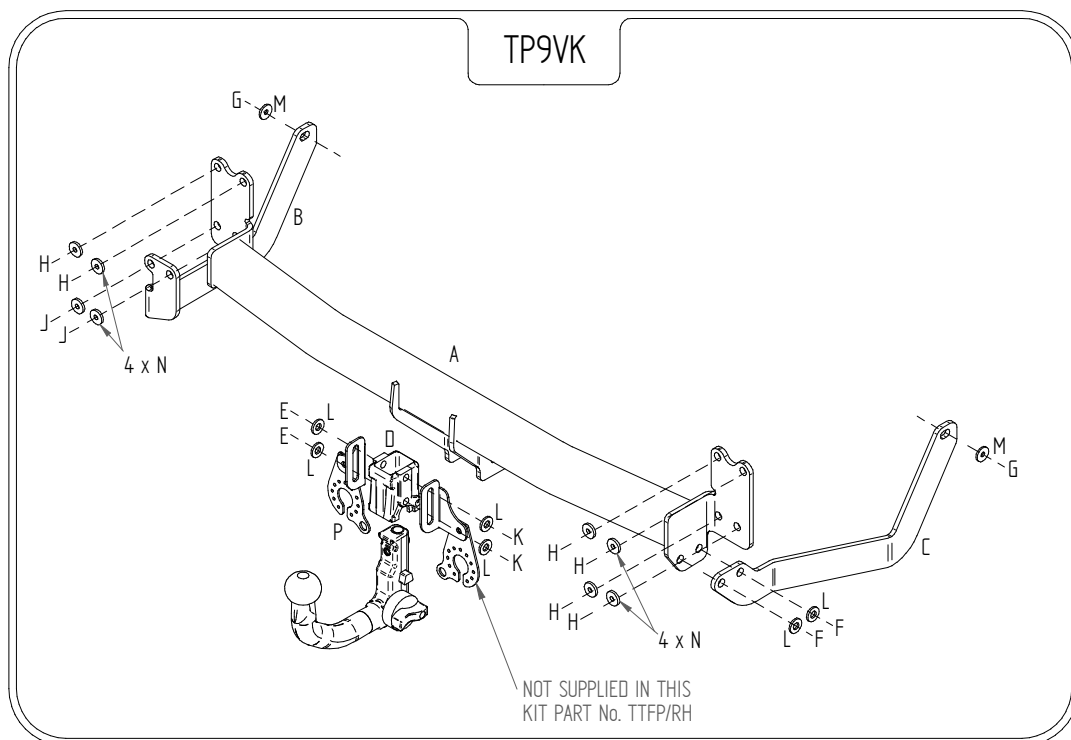

Note:

1. Recommended Torque Setting for M12 Grade 10.9 -139 Nm. (For other Torque Settings see notes overleaf.)
2. Nose load limits and vehicle manufacturers trailer / caravan weight limits must be observed.