



Tow-Trust Towbars

Important: Please read General Notes overleaf before fitting

Issue 1

TR 813 Renault Laguna 5 person & 7 Person '95>

A	1	Crossbar	F	4	M16 x 50 Bolts, Nuts & S/P Washers
B	2	Handed Side Arms	G	2	M10 Nuts & S/P Washers
C	1	Extension Bar	H	4	M12 x 30 Bolts, 2 Nuts & 4 Washers
D	1	19 x 48 Tube	I	4	M8 x 35 Bolts, SP & Flat Washers
D1	1	17 x 48 Tube	J	2	10 x 50 Flat Washers
E	4	M8 Caged Nuts	K	2	Bolt caps

1. Remove the rear exhaust hanger and the two bolts securing the forward heat shield.
2. Locate the four existing holes in the rear panel and insert the four caged nuts (item **E**).
3. Locate the existing holes in each chassis member, using item **G** loosely bolt item **B** with item **D** and item **D1** inside the chassis (5 seater models only) and item **J** on the outer face.
4. Using item **I** loosely bolt item **B** to the caged nuts (item **E**) in the rear panel.
5. Using item **H** loosely bolt item **A** to item **B**.
6. Fully tighten all nuts and bolts, starting with item **I** (the M8's x 35's) and ensure the towbar is rigid and secure.
7. Replace the heat shield and exhaust hanger.
8. Using item **F** bolt item **C** to item **A**.
9. Using item **F** bolt the ball bracket and wiring plate (not supplied in this kit) to the mounting plate.

Note: nose load limits and vehicle manufactures trailer / caravan weight limits must be observed.

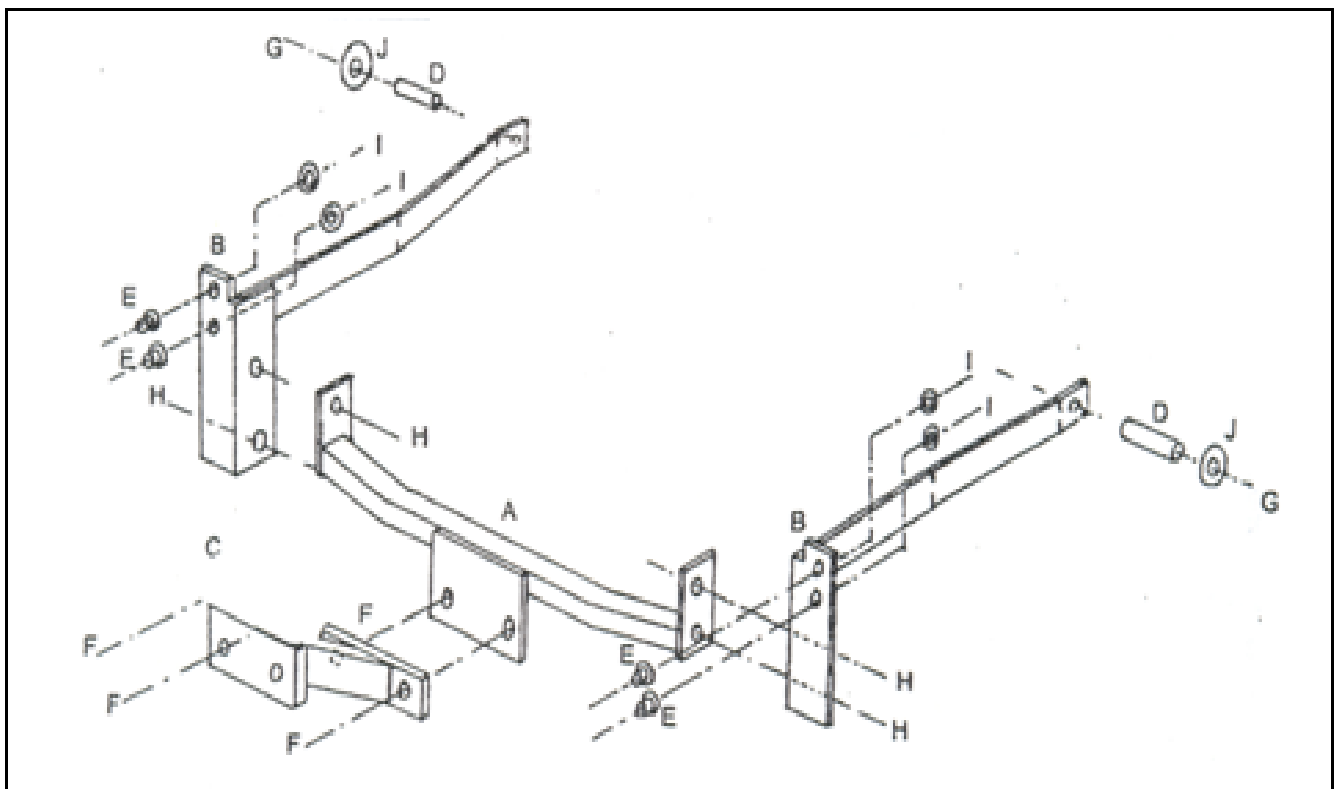

Tow with Trust