

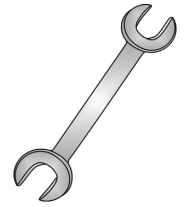

# Tow-Trust Towbars

Important: Please read General Notes overleaf before fitting



Issue 2

## TR858AVK RENAULT MEGANE SPORTS TOURER ESTATE 2009>

Item	Qty	Description	Item	Qty	Description
A	1	Crossmember	E	1	Flip Up Socket Plate
B	1	L/H Side Arm	F	2	M12 x 25 Bolts & S/P Washers
C	1	R/H Side Arm	G	2	M12 x 35 Bolts, Nuts & S/P Washers
D	1	Detachable Housing	H	2	M12 x 45 Bolts & S/P Washers
			J	2	M10 x 35 Bolts & S/P Washers
			K	6	12 x 25 Flat Washers
			L	2	12 x 40 Flat Washers
			M	2	10 x 40 Flat Washers
			N	2	M12 x 22 Bolts & S/P Washers

1. Temporarily disconnect and remove the rear light clusters (three nuts and pull clusters rearward).
- 2A. Remove the rear bumper; Six fixings around each light cluster, Seven fixings along the underside, and three fixings on the rear side of each wheel arch (one of these are behind each mud flap), (Pull bumper outwards and upwards then rearward). NOTE: These are only a guide.
2. Remove reinforcement beam (this is not refitted with the towbar).
3. Remove the rubber chassis covers, left hand side bumper stiffener, spare wheel and jack assembly.
4. Locate Item B into the left hand chassis and Item C into the right hand chassis and using Item J with Item M loosely bolt to the existing forward most holes in each chassis member. Note: existing holes in chassis are covered in tape.
5. Using Item H with Item L (forward hole) and Item G with Item K (rear hole) loosely bolt Item A to Item B and Item C. Note: access for tightening Item H is on the left hand side, gained by lifting loading lip plastic trim inside the boot and removing the four fixings hidden under the plastic caps, move aside rear side panel and foam and remove blanking plug on the outer skin of the rear wing, or by temporarily removing the air vent on the side of the chassis panel.
6. Fully tighten all nuts and bolts and ensure the towbar is rigid and secure.
7. Note: it is recommended the open ends of the chassis are resealed to prevent water damage.
8. Temporarily bend bumper tags down and replace the bumper.
9. Refit all trim, accessories and light clusters.
10. Using Item F with Item K and Item N with Item K bolt Item E and Item D to Item A.

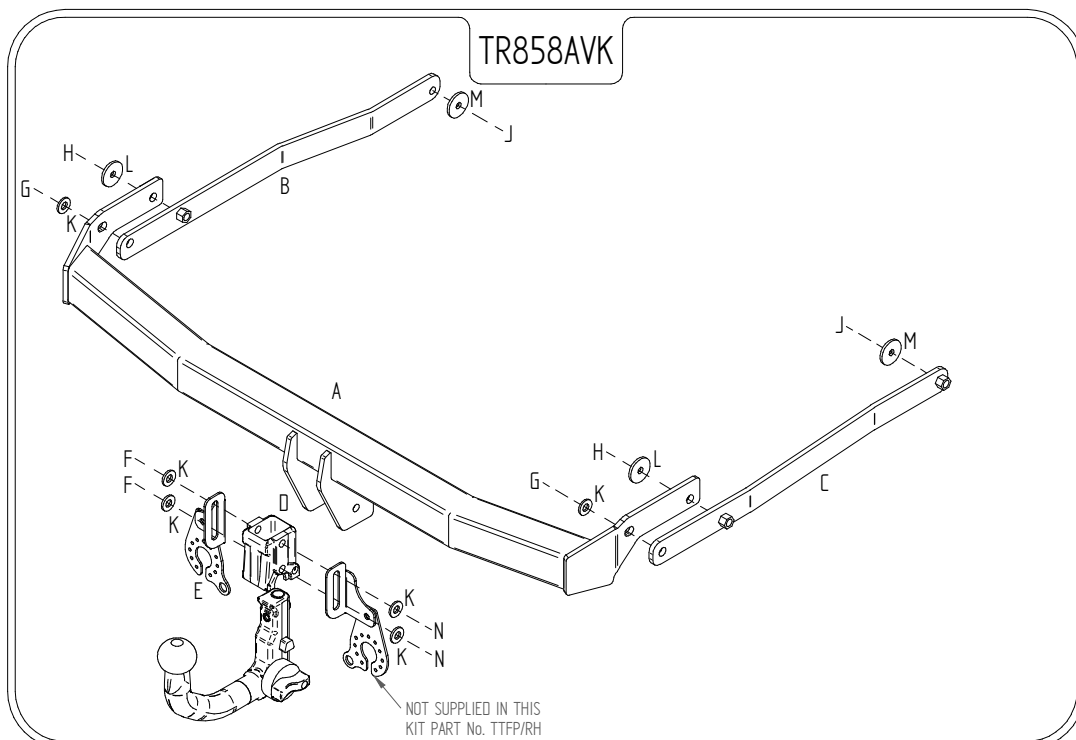

**Note:**

1. Recommended Torque Setting for M12 Grade 10.9 -139 Nm. (For other Torque Settings see notes overleaf.)
2. Nose load limits and vehicle manufacturers' trailer / caravan weight limits must be observed.