



# Tow-Trust Towbars

Important: Please read General Notes overleaf before fitting

Issue 8

## TST 1050A SEAT ALTEA 2004> TOLEDO 2004> LEON 2005> SKODA YETI 2009>

Item	Qty	Description	Item	Qty	Description
A	1	Crossmember	C	2	M16 x 50 Bolts, Nuts & S/P Washers
A1	2	Handed Side Arms	D	8	M12 X 35 Bolts, 2 Nuts & 8 S/P Washers
B	1	Extension Bar	E	2	M12 x 85 Grade 10.9 Bolts & Nyloc Nuts
			F	6	12 x 25 Flat Washers
			F1	4	12 x 40 Flat Washers

- Temporarily remove the rear light clusters. **Altea/Toledo/Leon.** Remove panel from inner trim and remove plastic nut from the back of each light. Remove two fixings through the plastic trim to the inner side and then pull the light clusters rearward.
- Temporarily disconnect the fog lights, reverse light and if fitted reversing sensors.
- Remove the rear bumper:-  
**ALTEA** - Eight fixings along the bottom edge, five fixings around each wheel arch. (top fixing is below the trim) two fixings under each light cluster. Pull bumper rearward.  
**TOLEDO** - Seven fixings along the bottom edge, five fixings around each wheel arch. (Top fixing is below the trim) two fixings under each light cluster. Pull bumper rearward.  
**LEON** - Seven fixings along the bottom edge, four fixings around each wheel arch. (Top fixing is below the trim) three fixings under each light cluster. Pull bumper out at sides.
- Cut bumper as shown in sketch and if required trim to suit. (SKODA YETI 75 WIDE X 90 DEEP)  
(LEON ECOMOTIVE 70 WIDE X 120 DEEP. STILL INVISIBLE CUT)
- Remove the bumper beam and replace existing bolts to prevent water damage.
- Locate Item **A1** into the open ends of each chassis member and using Item **D** with Item **F1** loosely bolt through existing holes in each chassis member. (Existing holes may be covered in tape.)
- Using item **D** bolt item **A** to item **A1**.
- Fully tighten all nuts and bolts and ensure the towbar is rigid and secure.
- Refit bumper and light clusters.
- Using Item **E** with Item **F** bolt Item **B** to Item **A**.
- Using item **C** bolt the ball bracket and wiring plate (not supplied in this kit) to the mounting plate.

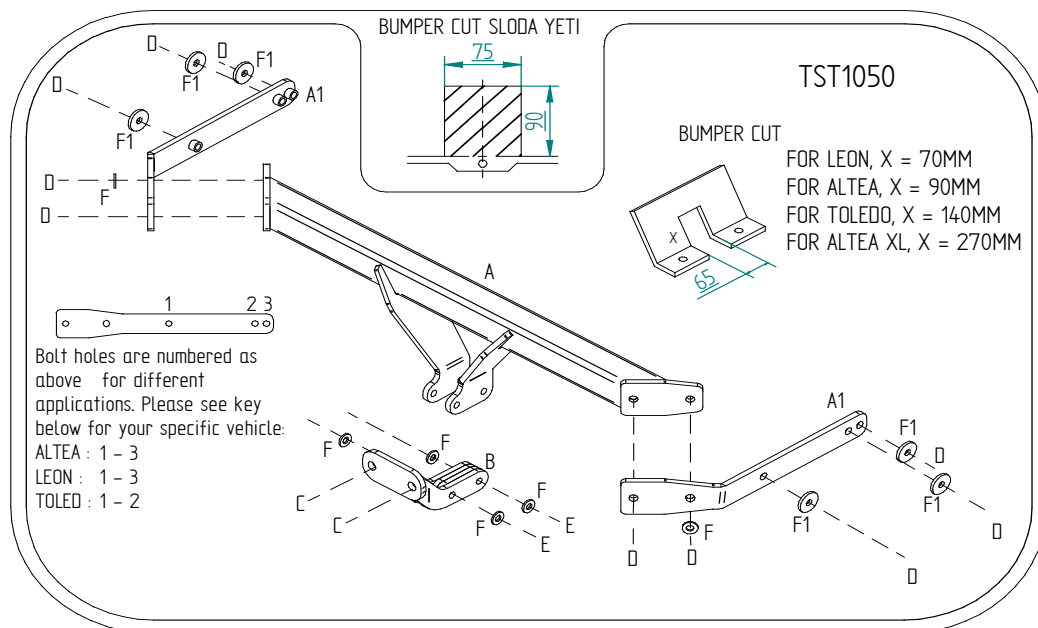

### Note:

- Recommended Torque Setting for M12 Grade 10.9 -139 Nm. (For other Torque Settings see notes overleaf.)
- Nose load limits and vehicle manufacturers trailer / caravan weight limits must be observed.