



Tow-Trust Towbars

Important: Please read General Notes overleaf before fitting

ISSUE 1

TSY2 SSANGYONG KYRON 2006>

Item	Qty	Description	Item	Qty	Description
A	1	Crossmember	H	2	M16 x 50 Bolts Nuts & Washers
B	1	Extension Bar	J	2	M14 x 140 Bolts & Washers
C	1	R/H Side Arm	K	6	M12 x 40 Bolts, 2 Nuts & Washers
D	1	L/H Side Arm	L	4	M10 x 30 Bolts, Nuts & Washers
E	2	Spacer Tubes	M	2	M8 x 25 x Bolts, Nuts & Washers
F	2	Captive Clamp Plates	N	2	M12 x 22 Bolts & Washers
G	2	Bumper Brackets	P	2	M12 x 100 Bolts & Nyloc Nut
			R	12	12 x 25 Flat Washers
			S	4	14 x 27 Flat Washers
			T	2	8 x 25 Flat Washers

1. Remove rear light clusters.
2. Remove the rear bumper, seven fixings from the wheel arches, two fixings from the black brackets, seven fixings on the top edge of the bumper and two fixings from the lower edge. (Disconnect reversing sensors if fitted).
3. Remove the rear crash beam and foam packer (These are not refitted with the Towbar).
4. Insert item **E** into the open ends of each chassis members and align with the existing Towbar mounting points.
5. Using item **J** with item **S** loosely bolt item **C** and item **D** to the lower face of each chassis clamping the top face with items **F**.
6. Using items **K** with items **R** and item **L** bolt item **A** up to items **C** and **D** fitting items **G** to the lower rearmost bolt. SEE SKETCH.
7. Using item **N** with item **R** and item **P** with item **R** bolt item **B** to item **A**.
8. Fully tighten all nuts and bolts and ensure Towbar is rigid and secure.
9. Cut the rear bumper centrally 80mm wide and 50mm deep if required trim to suit.
10. Refit the rear bumper and light clusters to the vehicle.
11. Using item **M** with item **T** re-fix the rear bumper to the lower brackets and fully tighten.
12. Using item **H** fit the ball bracket and wiring plate (not supplied in this kit) to item **B** and fully tighten.

Note:

Recommended Torque Setting for M12 Grade 10.9 -139 Nm. (For other Torque Settings see notes overleaf.)

Nose load limits and vehicle manufacturer's trailer / caravan weight limits must be observed.

TSY 2

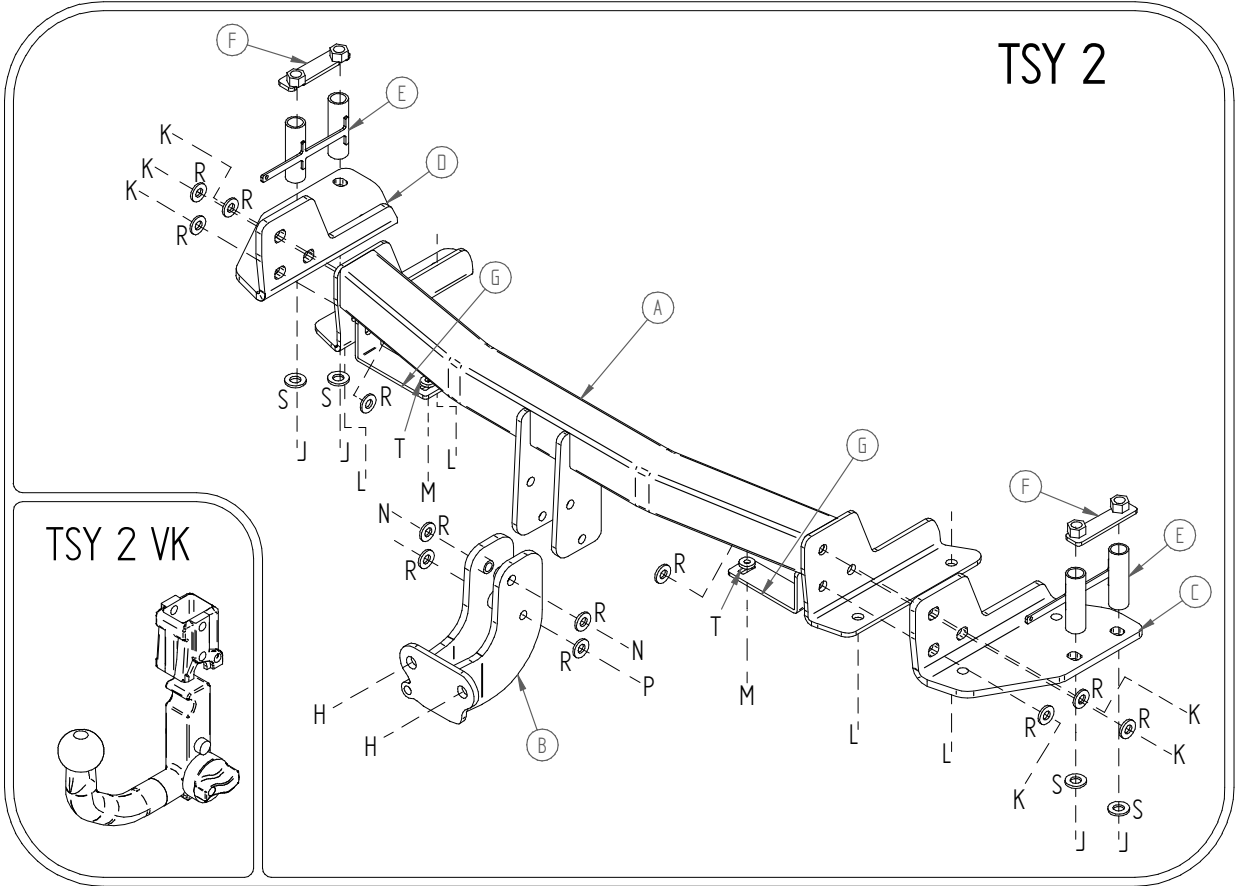

Tow with Trust