



Tow-Trust Towbars

Important: Please read General Notes overleaf before fitting

Issue 2

TV 2 VK VAUXHALL INSIGNIA ESTATE 2009>

Item	Qty	Description	Item	Qty	Description
A	1	Crossmember	F	2	M12 x 22 Bolts & Washers
B	1	L/H Side Arm	H	2	M12 x 25 Bolts & Washers
C	1	R/H Side Arm	J	4	M10 Nyloc Nuts
D	1	Detachable Housing	K	4	M10 x 45 Bolts Grade 10.9 & Washers
E	1	Flip Down Socket Plate	L	4	M12 x 40 Bolts, 2 Nuts & 4 Washers
			M	4	10 x 25 Flat Washers
			N	10	12 x 25 Flat Washers
			P	4	10 x 30 Flat Washers

1. Remove the rear bumper. Remove the tailgate guides (we advise that you mark the position of guides before you remove to ensure correct location when refitted) remove three fixings in each wheel arch and three fixings on the lower edge,
2. Remove the six fixings securing the impact beam to the rear panel.
3. Lower the exhaust from its rearmost hanger. (Two fixings on the back panel).
4. Identify all Towbar mounting points and clear of any under seal or mastic.
5. Place item **B** into the N/S Chassis and item **C** into the O/S chassis and using item **K** with item **P** loosely bolt through the vertical mounting points on the lower face of each chassis member.
6. Using item **J** with item **M** loosely bolt each side arm (items B & C) to the captive studs on the rear panel.
7. Using item **L** with item **N** bolt item **A** between item **B** and item **C**.
8. Fully tighten all nuts and bolts ensuring Towbar is rigid and secure.
9. Refit the foam bumper support to item **A**.
10. Cut out Vauxhalls pre marked area of bumper for the Towbar assembly to pass through.
11. We recommend you locate your desired wiring kit (Not supplied in this kit) into the vehicle now as it may be difficult to enter the vehicle once the bumper is refitted.
12. Refit the exhaust and rear bumper.
13. Using item **G** with item **N** and item **H** with item **N** bolt item **E** and item **D** to item **A**.
14. Using item **F** bolt the ball bracket (Not supplied in this kit) to item **D** and fully tighten all remaining nuts and bolts.

Note: nose load limits and vehicle manufacturer's trailer / caravan weight limits must be observed.

M10 Grade 10.9 = 60Nm

TV2 VK

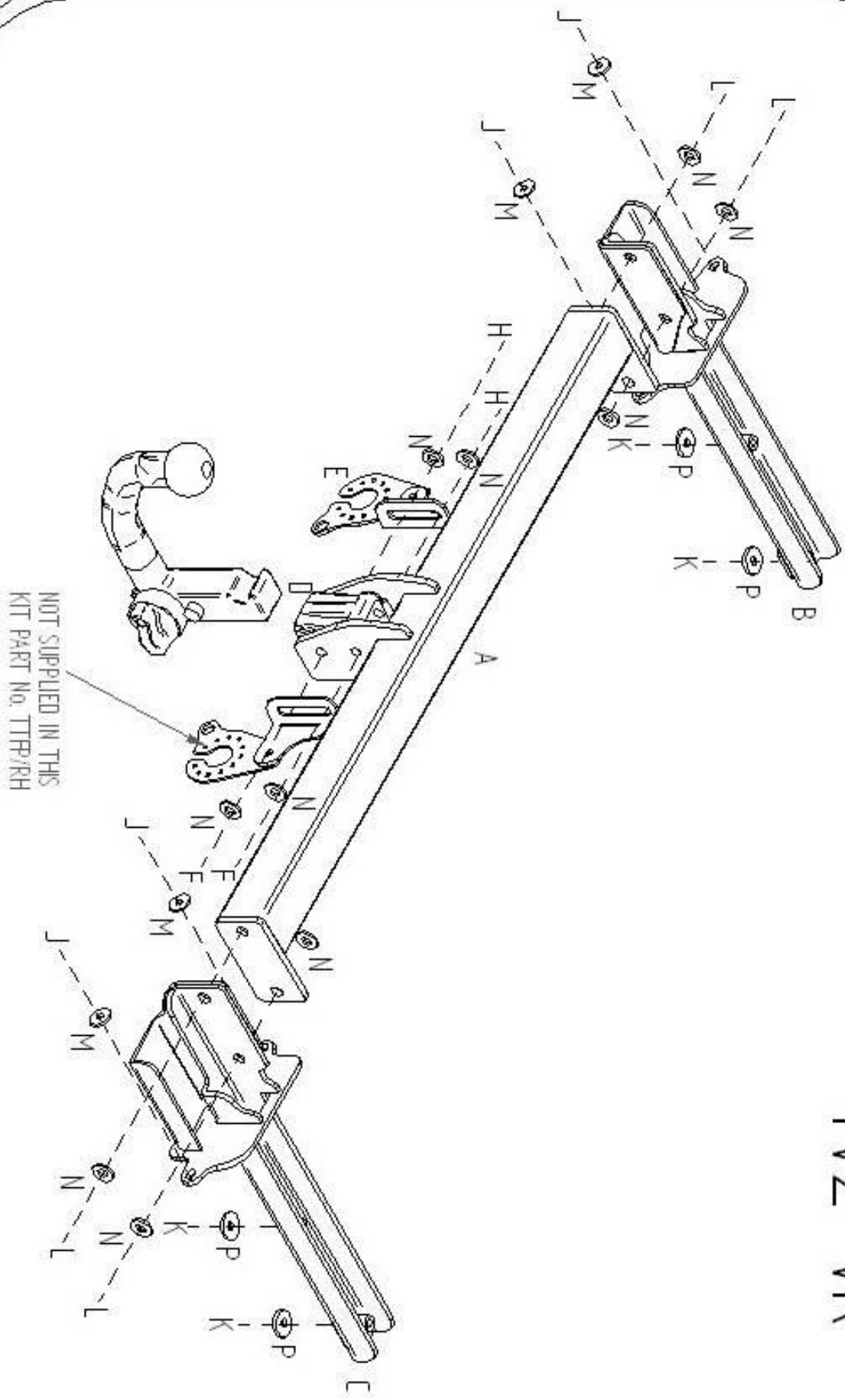

Tow with Trust