



Tow-Trust Towbars

Important: Please read General Notes overleaf before fitting

Issue 1

TV336 Vauxhall Corsa Hatchback 1993 - 1998

Item	Qty	Description	Item	Qty	Description
A	2	Clamp Plates	F	2	M16 x 45 Bolts, Nuts & S/P Washers
B	1	Bracing Stay	F	11	M10 x 35 Bolts, Nuts & S/P Washers
C	1	Angle Bracket	G	2	M10 x 35 Bolts, Nuts & S/P Washers
D	1	Drop Plate	H	3	10 x 40 Washers

1. Remove the rear bumper, from bottom edge and central, cut a piece out 140mm wide and 50mm this will allow the drop plate to come through, remove the metal impact beam, remove the spare wheel.
2. Remove the trim from the inside face of the back panel, locate the four dimples and drill out to 11mm.
3. Using item F bolt items A to the rear panel (one side the boot, the other on the outside) using the holes in item A as jigs drill two 11mm holes through the rear panel.
4. Using item G loosely bolt item D to the outer face of item A, using item F bolt item B to item D.
5. Using item F bolt item C to item B centralise the towbar and using the holes in item C as jigs drill three 11mm holes up into the spare wheel pan, using item F with item H under each bolt head, bolt item C into place.
6. Using item E bolt the ball bracket and wiring plate (not supplied in this kit) to the mounting plate.
7. Fully tighten all nuts and bolts and ensure the towbar is rigid and secure.
8. Replace the impact beam, bumper and spare wheel.

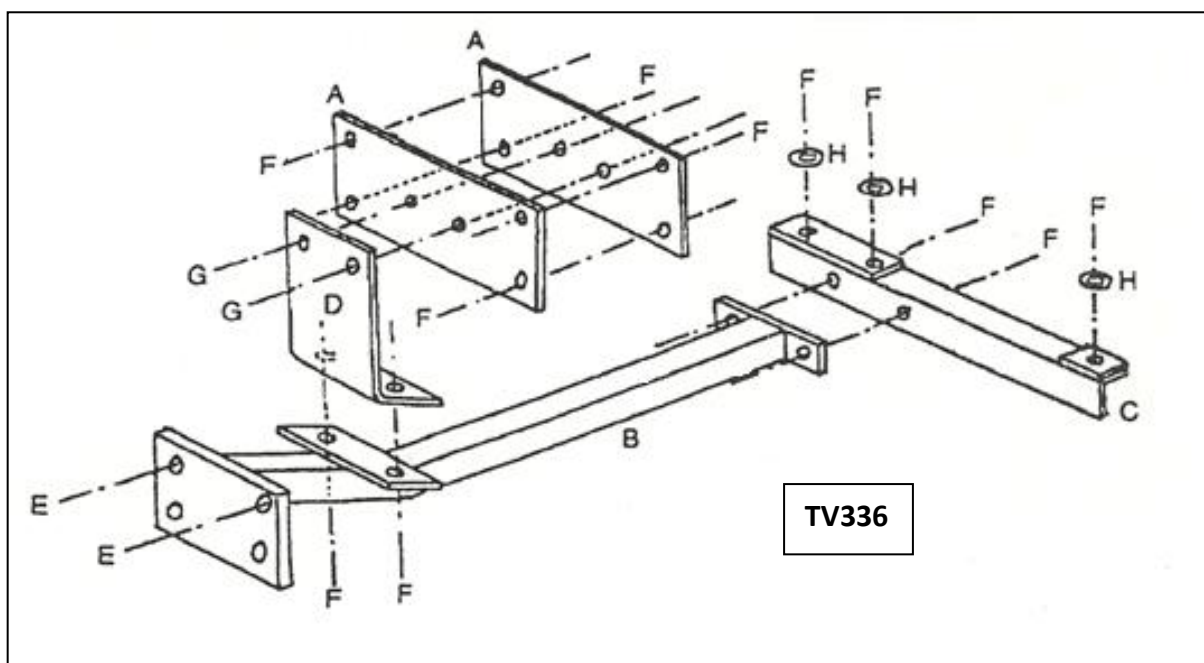

Note:

1. Recommended Torque Setting for M12 Grade 10.9 -139 Nm. (For other Torque Settings see notes overleaf.)
2. Nose load limits and vehicle manufacturer's trailer / caravan weight limits must be observed.