



Tow-Trust Towbars

Important: Please read General Notes overleaf before fitting

Issue 1

TVV 517A Volvo S7-V70 '97>

Item	Qty	Description	Item	Qty	Description
A	1	Crossmember	F	4	M16 x 50 Bolts, Nuts & S/P Washers
B	1	Extension Bar	G	12	M8 x 35 Bolts, Nuts & S/P Washers
C	2	Angle Plates	H	4	M12 x 55 Bolts & S/P Washers only
D	3	Clamp Plates with Captive Nuts	J	2	M10 x 55 Bolts & S/P Washers only
E	2	Straps with Captive Nuts	K	4	12 x 25 Flat Washers
			L	2	10 x 25 Flat Washers
			M	20	8 x 25 Flat Washers
			N	6	Rivets

1. Drill out the rivets securing the wheel arch liners to the bumper. Remove the bumper, before removing the bumper support brackets mark them so that when replaced they go back in the same position.
2. Remove the rear exhaust hanger (the upper section is no longer required).
3. Using item **G** with item **M** loosely bolt item **C** to the existing holes in the rear panel.
4. Locate item **D** inside each chassis member over the existing rear holes (two on the R/H side and one on the L/H side).
5. Using item **H** with item **K** loosely bolt item **A** into position.
6. Locate item **E** into the ends of each chassis member and using item **J** with item **L** bolt item **A** at the forward holes.
7. Fully tighten all nuts and bolts.
8. Using item **G** with item **M** bolt the lower exhaust bracket to the left hand side of item **A**.
9. Refit the bumper support brackets ensuring they are in the same position as before. Replace the bumper using the rivets provided secure the bumper back to the wheel arch liners.
10. Using item **F** bolt item **B** to item **A**.
11. Using item **F** bolt the ball bracket and wiring plate (not supplied in this kit) to the mounting plate.
12. Fully tighten all nuts and bolts and ensure the towbar is rigid and secure.

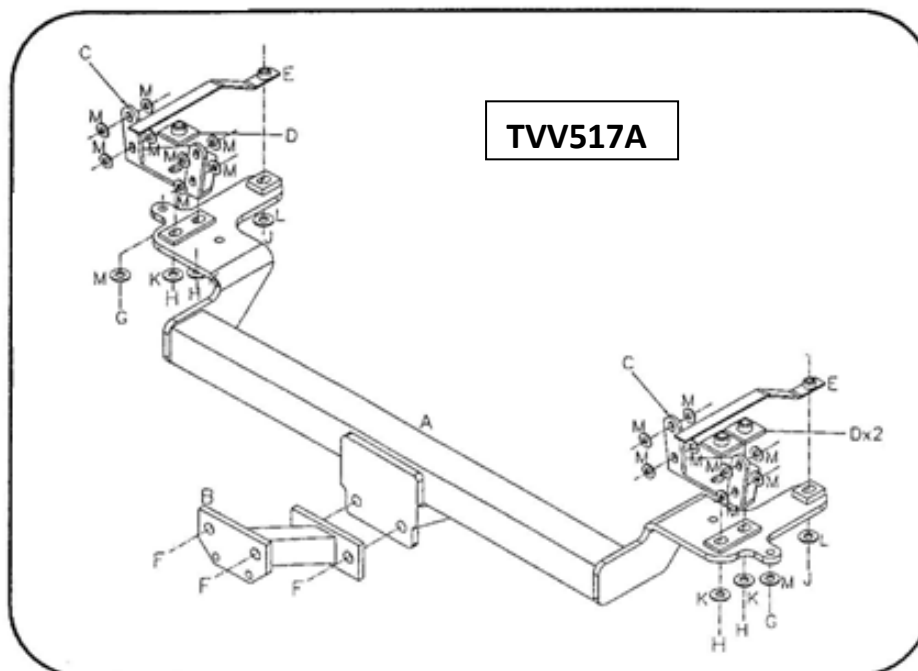

Note:

1. Recommended Torque Setting for M12 Grade 10.9 -139 Nm. (For other Torque Settings see notes overleaf.)
2. Nose load limits and vehicle manufacturer's trailer / caravan weight limits must be observed.