



Tow-Trust Towbars

Important: Please read General Notes overleaf before fitting

Issue 1

TVW605A Volkswagen Golf Vento & Van '92> (Not Convertible)

Item	Qty	Description	Item	Qty	Description
A	1	Towbar	B	2	M16 x 50 Bolts, Nuts & S/P Washers
			C	4	M10 x 35 Bolts & S/P Washers Only
			D	4	10 x 40 Flat Washers

1. Remove the rear bumper, cut a hole in the lower edge 50mm wide x 50mm deep.
2. Position the towbar into the ends of the chassis and bolt into place using item **C** with item **D** under each bolt head.
3. Replace bumper.
4. Using item **B** bolt the ball bracket and wiring plate (not supplied in this kit) to the mounting plate.
5. Fully tighten all nuts and bolts and ensure the towbar is rigid and secure.

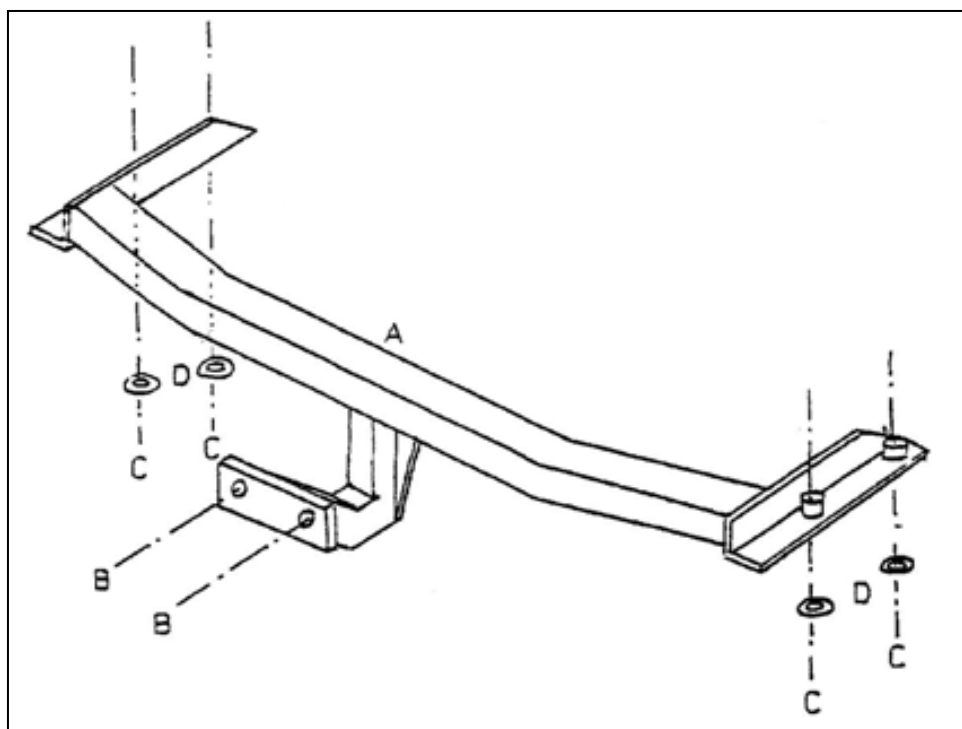

Note:

1. Recommended Torque Setting for M12 Grade 10.9 -139 Nm. (For other Torque Settings see notes overleaf.)
2. Nose load limits and vehicle manufacturer's trailer / caravan weight limits must be observed.