



Tow-Trust Towbars

Important: Please read General Notes overleaf before fitting

Issue 6

TVW 616

SEAT - AUDI - VOLKSWAGEN

Item	Qty	Description	Item	Qty	Description
A	1	Crossmember	F	4	M12 x 40 Bolts 2 Nuts & 4 S/P Washers
B	1	L/H Side Arm	G	2	M12 x 85 Grade 10.9 Bolts & Nyloc Nuts
C	1	R/H Side Arm	H	4	M10 x 35 Bolts & S/P Washers
D	1	Extension Bar	J	4	10 x 30 Flat Washers
E	2	M16 x 50 Bolts, Nuts & S/P Washers	K	8	12 x 25 Flat Washers

1. Remove the light cluster. Remove the rear bumper (torx head screws along the top edge, lower edge and around each wheel arch).
2. Remove the steel beam (this is no longer required). Replace the four original bolts back onto the vehicle.
3. Locate item **B** and item **C** into the open ends of each chassis member. Remove the tape covering the existing holes and using item **H** with item **J** loosely bolt item **B** and item **C** into place.
4. Using item **F** and item **K** bolt item **A** to item **B** and item **C**.
5. Using item **G** with item **K** bolt item **D** to item **A**.
6. Fully tighten all nuts and bolts and ensure the towbar is rigid and secure.
7. Cut a small section out of the lower edge of the bumper (see sketch) (**AUDI A3 NO CUT REQUIRED**).
8. Re-fit the bumper and light cluster.
9. Using item **E** bolt the ball bracket and wiring plate (not supplied in this kit) to the mounting plate.

Note:

1. Recommended Torque Setting for M12 Grade 10.9 -139 Nm. (For other Torque Settings see notes overleaf.)
2. Nose load limits and vehicle manufacturer's trailer / caravan weight limits must be observed.

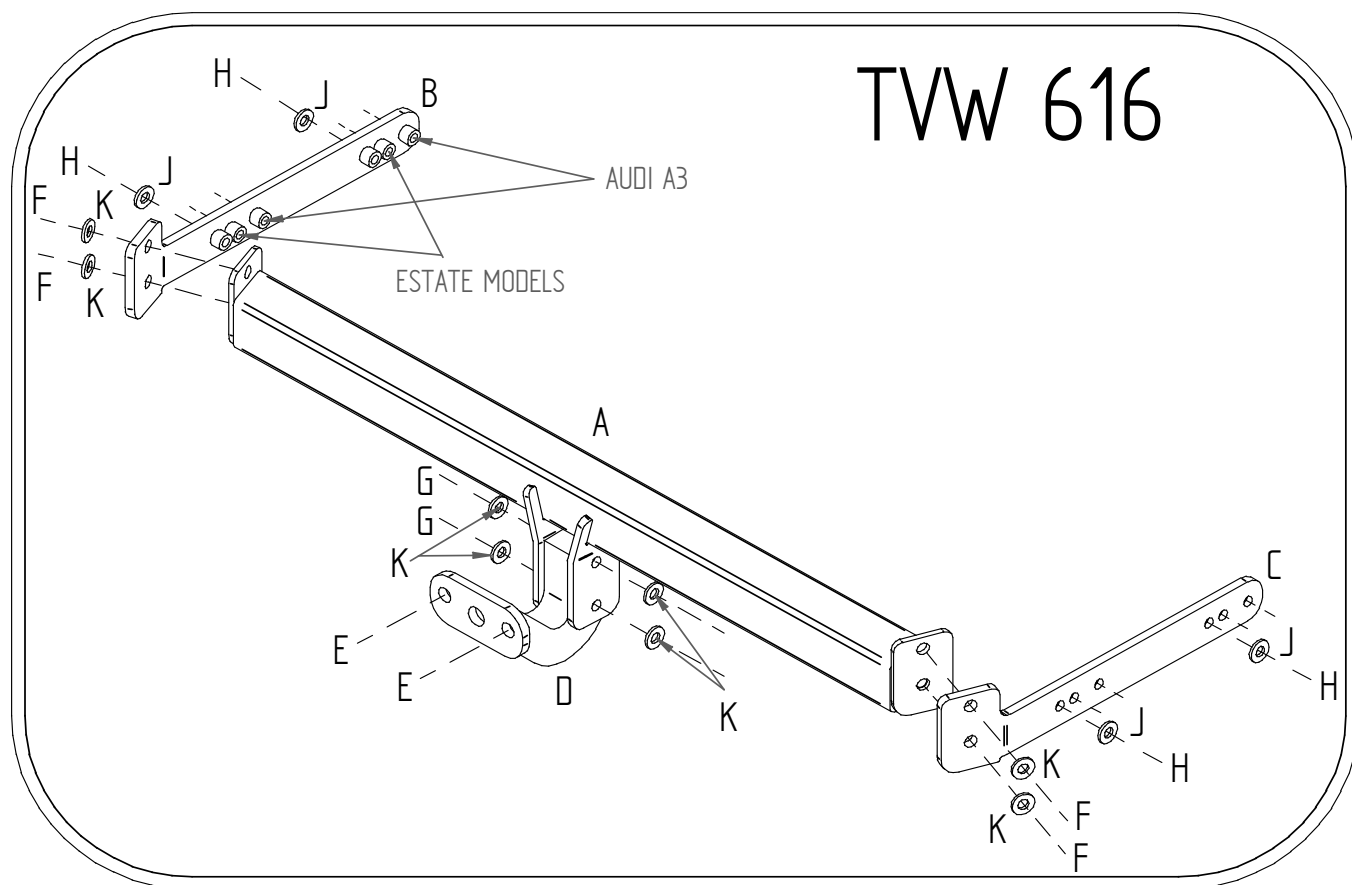

Type TVW616 SEAT 'LEON' BUMPER REMOVAL>

10. Remove inner back panel (inside boot) and both rear quarter trims.
11. Remove rear bumper. 9 torx on bottom edge. 5 torx each side (in-wheel arch). 4 10mm self tappers from inside boot along back panel.
12. Temporarily remove rear exhaust hanger to allow access to bolt hole.
13. Remove rear part of rear near side inner wheel arch (2 x torx) to allow access to front mounting bolt.
14. Cut out for bumper.

