



Tow-Trust Towbars

Important: Please read General Notes overleaf before fitting

Issue 5

TVW 620A Volkswagon T5 Transporter Van 2003>

Item	Qty	Description	Item	Qty	Description
A	1	Crossmember	D	2	M16 x 50 Bolts, Nuts & S/P Washers
B	1	Extension Bar	E	6	M10 x 35 Bolts & S/P Washers
			G	2	M12 x 85 Grade 10.9 Bolts & Nyloc Nuts
			H	4	12 x 25 Flat Washers
			J	6	10 x 30 Flat Washers

1. Lower the spare wheel.
2. Temporarily remove plastic cover from under the rear of the vehicle.
3. Temporarily remove the rear light clusters.
4. Remove rear bumpers and bumper shock insert. (This is not refitted with the towbar).
 Bumper Fixings (Twin Door Version)
 4 Plugs on bottom edge
 2 Plugs each rear corner under plastic covers
 2 Tip screws through plastic wheel arch liners
 1 further tip screw each side behind liner. Slide bumper rearwards
5. Locate Item **A** into the open ends of each chassis and using Item **E** with Item **J** loosely bolt into place through existing holes.
6. Fully tighten all nuts and bolts and ensure the towbar is rigid and secure.
7. Refit bumper, light clusters and spare wheel.
8. Using Item **G** with Item **H** bolt Item **B** to Item **A**.
9. Using Item **D** bolt the ball bracket (not supplied in this kit) to the mounting plate.

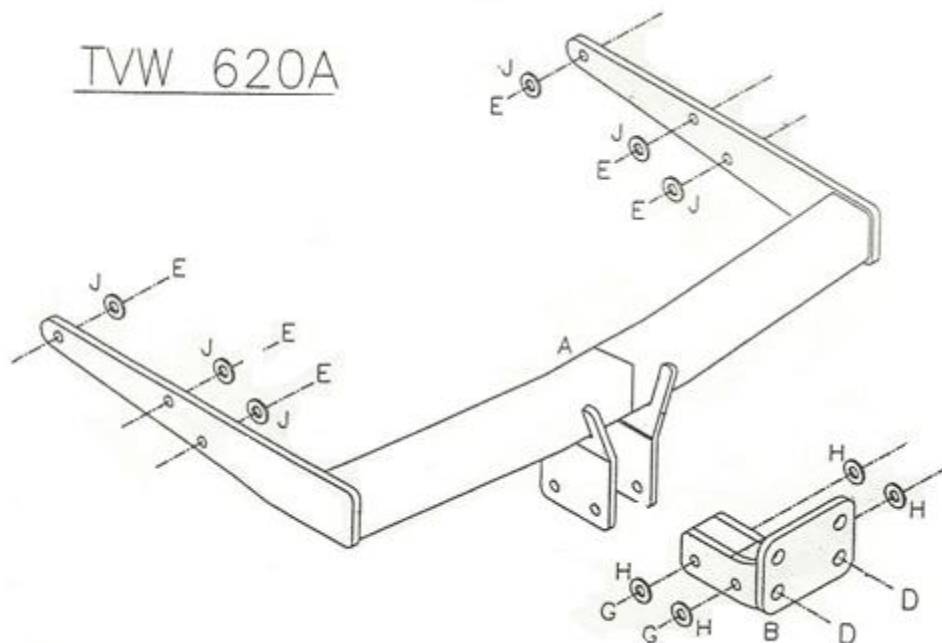

Note:

1. Recommended Torque Setting for M12 Grade 10.9 -139 Nm. (For other Torque Settings see notes overleaf.)
2. Nose load limits and vehicle manufacturer's trailer / caravan weight limits must be observed.