



Tow-Trust Towbars

Important: Please read General Notes overleaf before fitting

Issue 5

TVW625 VK

VOLKSWAGON PASSAT 2005>

Item	Qty	Description	Item	Qty	Description
A	1	Towbar	D	4	M12 x 40 Bolts & S/P Washers
B	1	Detachable Housing	E	2	M12 x 22 Bolts & S/P Washers
C	1	Flip Up Socket Plate	F	2	M12 x 25 Bolts & S/P Washers
			G	4	12 x 25 Flat Washers
			H	4	12 x 30 Flat Washers

1. Remove the rear light clusters. **PASSAT SAL & EST:** (Fixings found behind plastic trim on the side of cluster) **PASSAT CC:** (Three fixings internal of boot)
2. Remove the rear bumper. Four fixings around each wheel arch, one fixing at each bumper tip, two fixings below each light cluster and fixings along lower edge. (**NOTE:** PASSAT CC HAS HIDDEN FIXING AROUND WHEEL ARCH).
3. Pull each side of the bumper to remove off sliders.
4. Cut a section from the lower edge of the bumper (see sketch) trim to suit.
5. Remove the bumper beam. (this is not refitted with Towbar)
6. Temporarily lower the exhaust heat shield.
7. Remove the tape from the outer face of each chassis member covering Towbar mounting points.
8. Locate item **A** into the open ends of each chassis member and using item **D** with item **H** bolt in place through mounting points.
9. Using item **E** with item **G** and item **F** with item **G** bolt item **B** and item **C** to item **A**.
10. Fully tighten all nuts and bolts ensuring Towbar is rigid and secure.
11. Re-fit exhaust heat shield, rear bumper and light clusters.

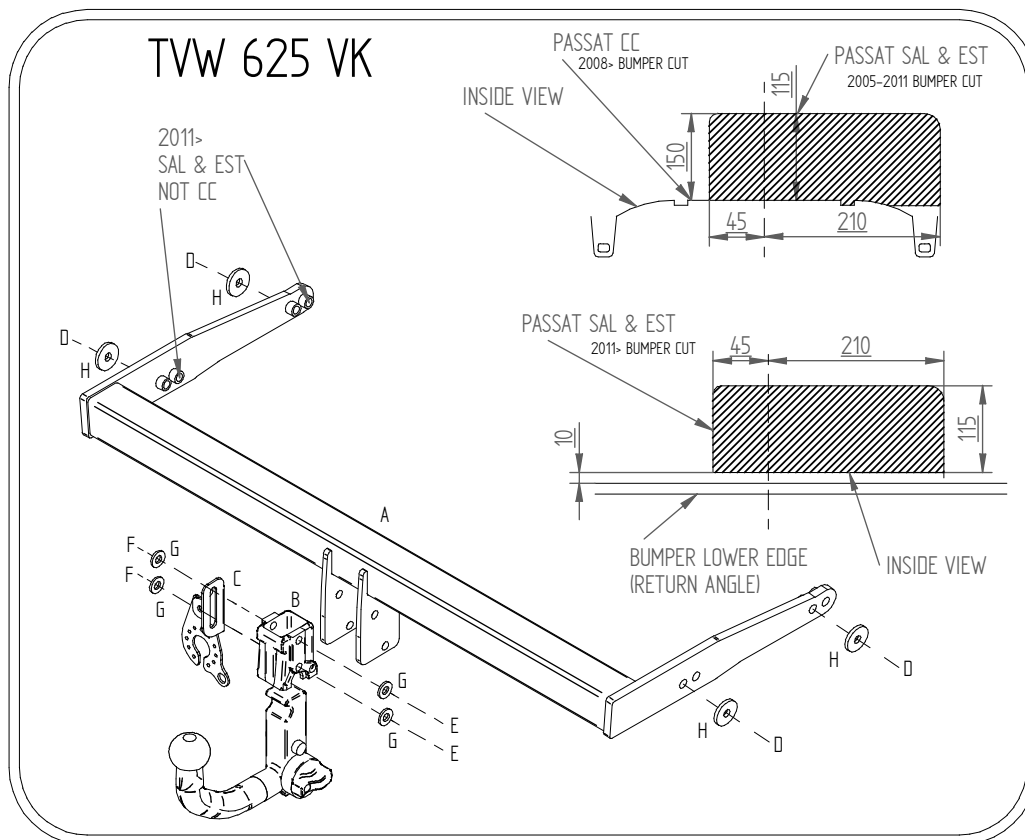

Note:

1. Recommended Torque Setting for M12 Grade 10.9 -139 Nm. (For other Torque Settings see notes overleaf.)
2. Nose load limits and vehicle manufacturer's trailer / caravan weight limits must be observed.